

# Holmen Investor Day 2022

11 May 2022

# Growing a sustainable future



**Our business concept is  
to own and add value  
to the forest**

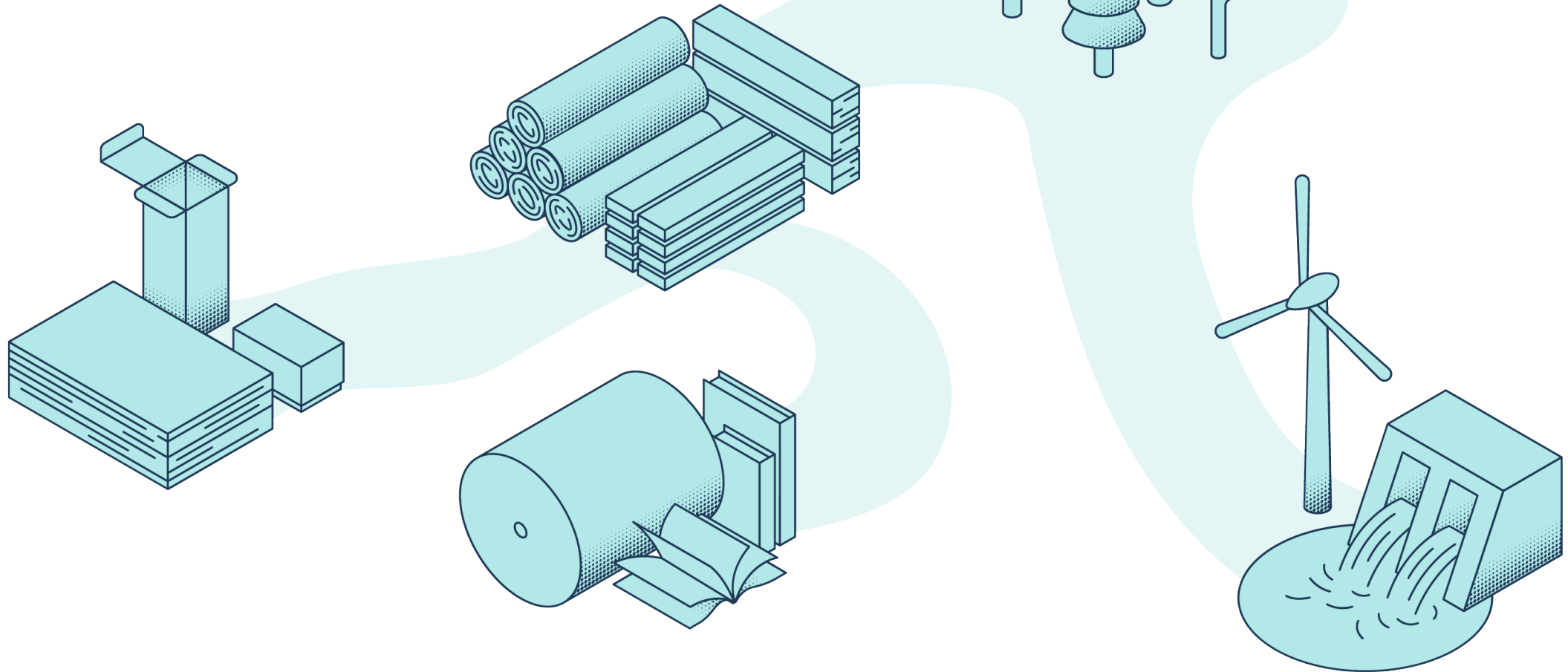

# Renewable Energy

1.7 TWh per year

The Renewable Energy business will grow by establishing wind power on Holmen's own land



# Hydro power production

$$\text{Effect (kW)} = H \times 9.81 \times Q$$

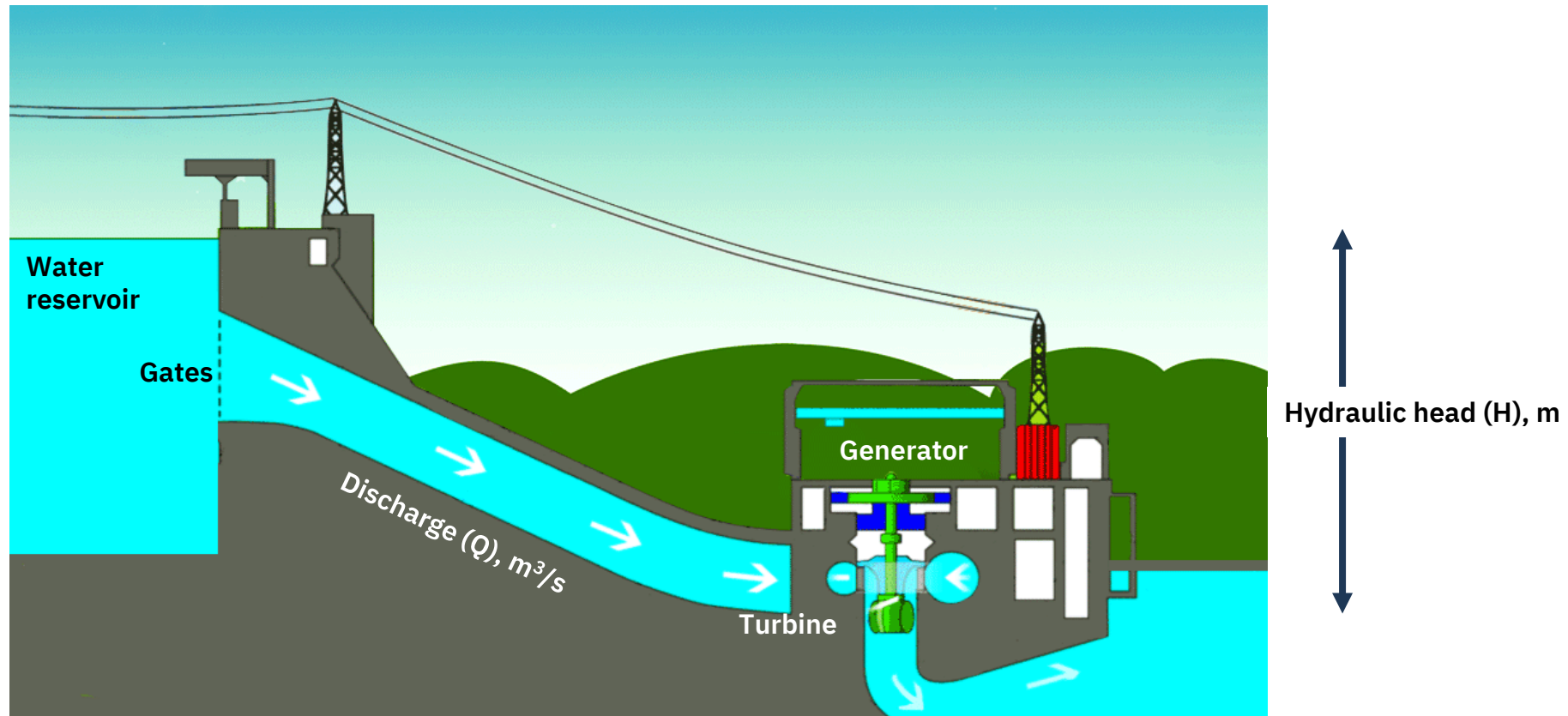

# Frequency regulation



Consumer

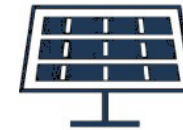
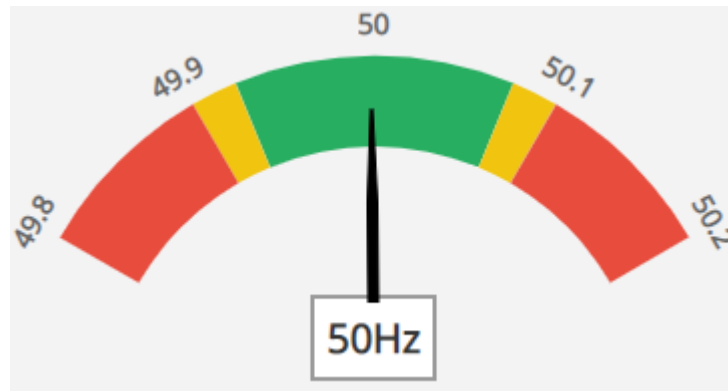

Producer

A night landscape featuring the aurora borealis (Northern Lights) in shades of green and yellow, arching across a dark sky filled with stars. Below the lights, a city is illuminated with warm yellow lights, visible through a valley. The foreground shows a snowy, rocky hillside with some evergreen trees. A solid teal rectangular bar is positioned at the top of the image.

# The energy market

# Hydro power EBIT has averaged SEKm ~300

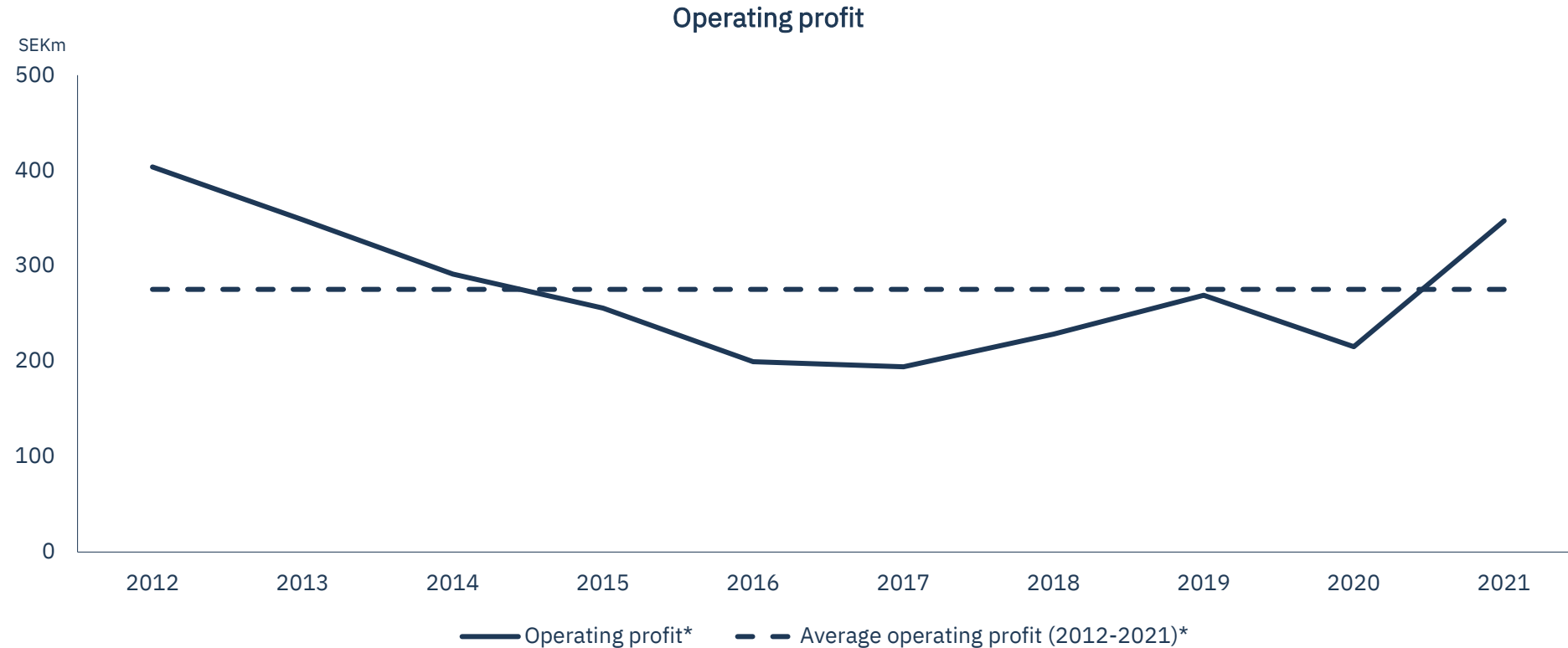



# World's growth fuelled by oil, coal & gas

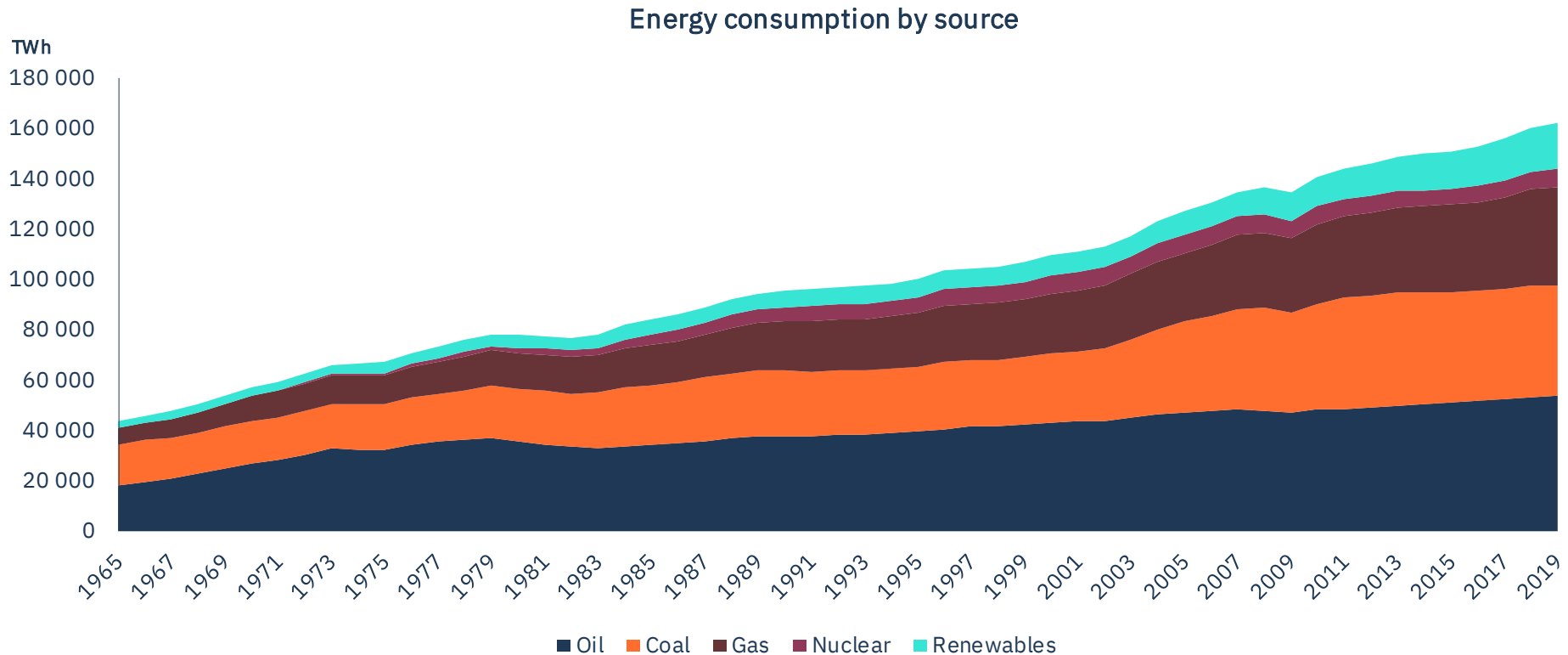

# EU heavily dependant upon fossil fuels

## 1/3 is imported from Russia

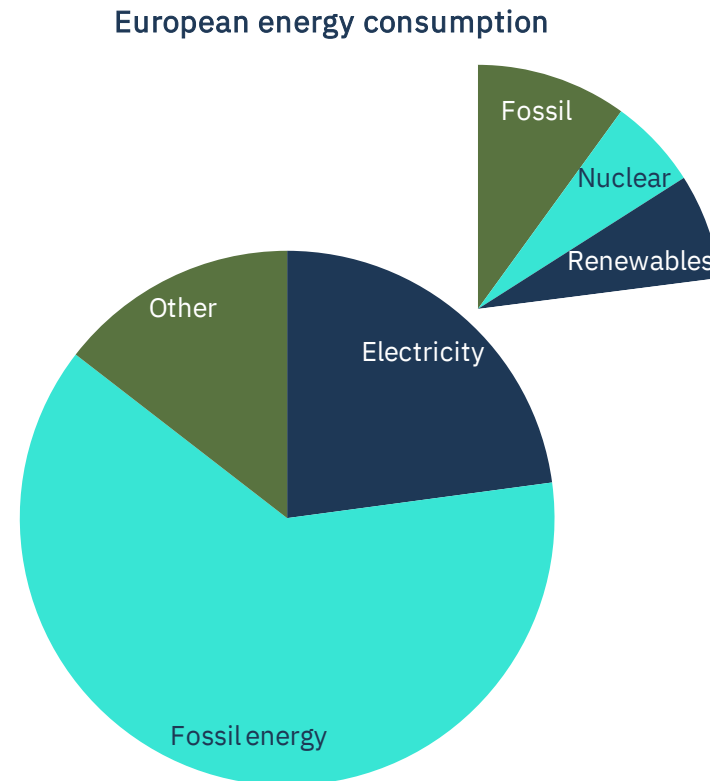

# Nordics are frontrunners in electrification

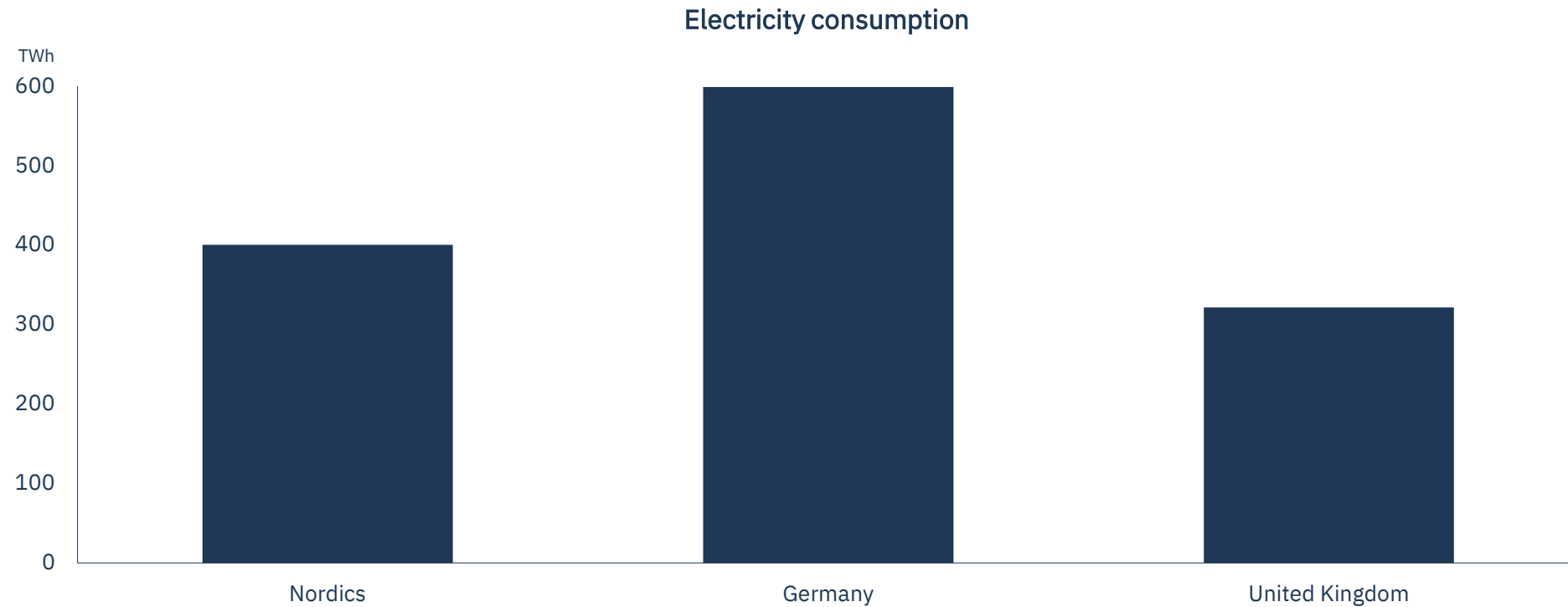

# Housing and industrial processes not yet electrified on the continent

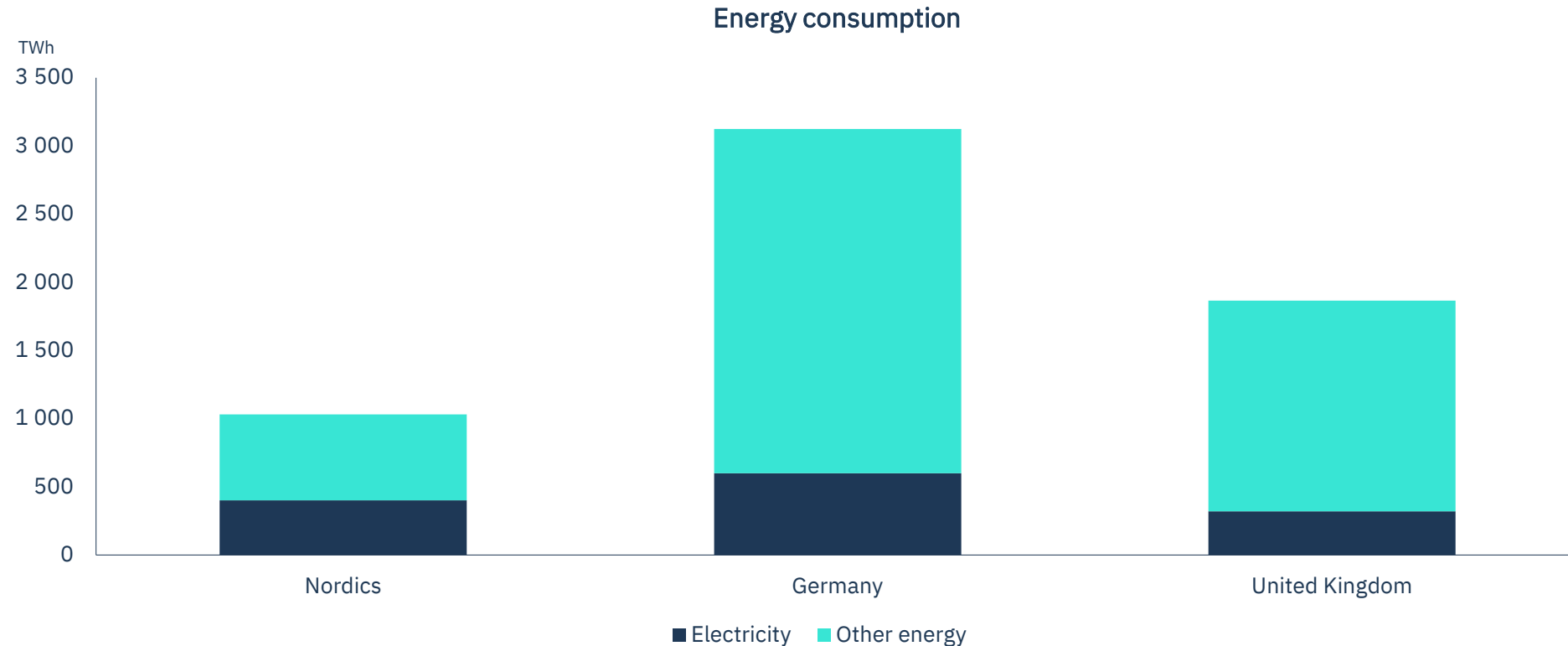

# Energy crunch in mainland Europe

## Surplus energy in northern Sweden

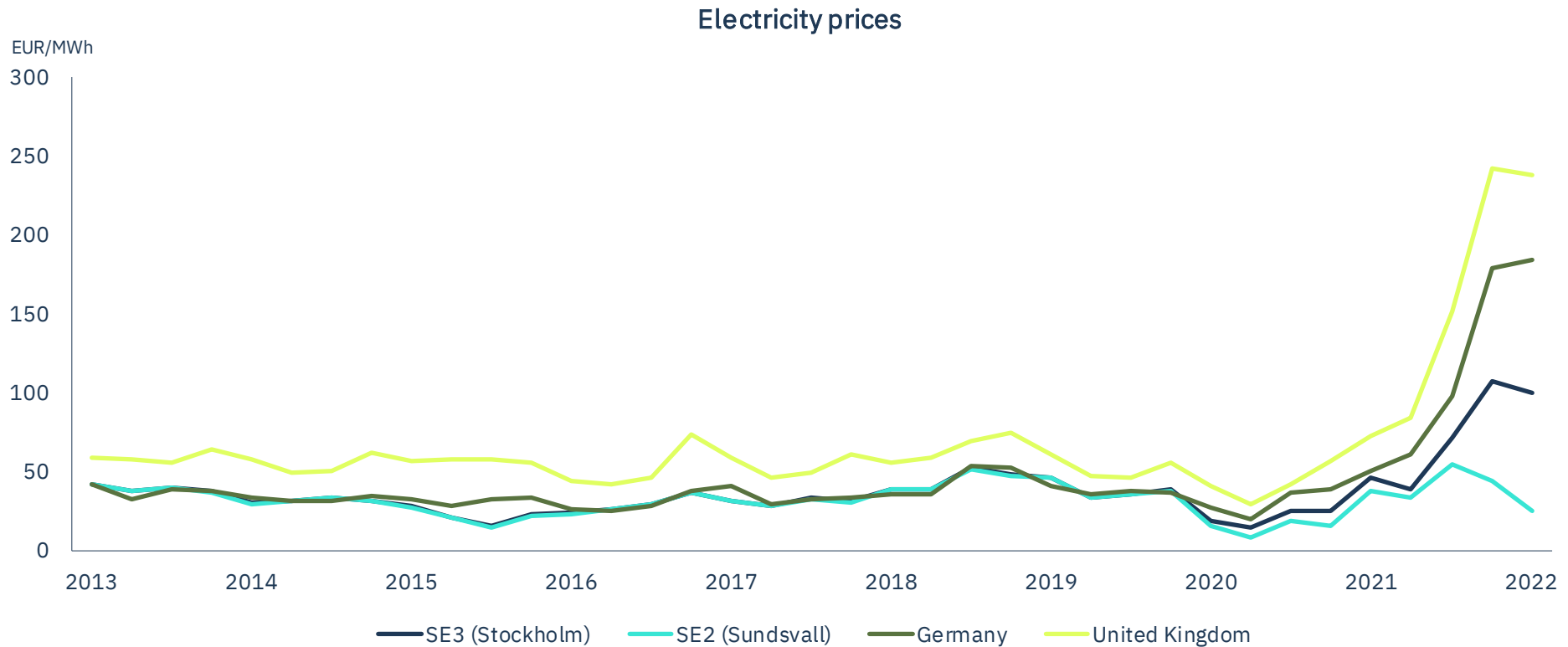

# Limitations in transmission capacity

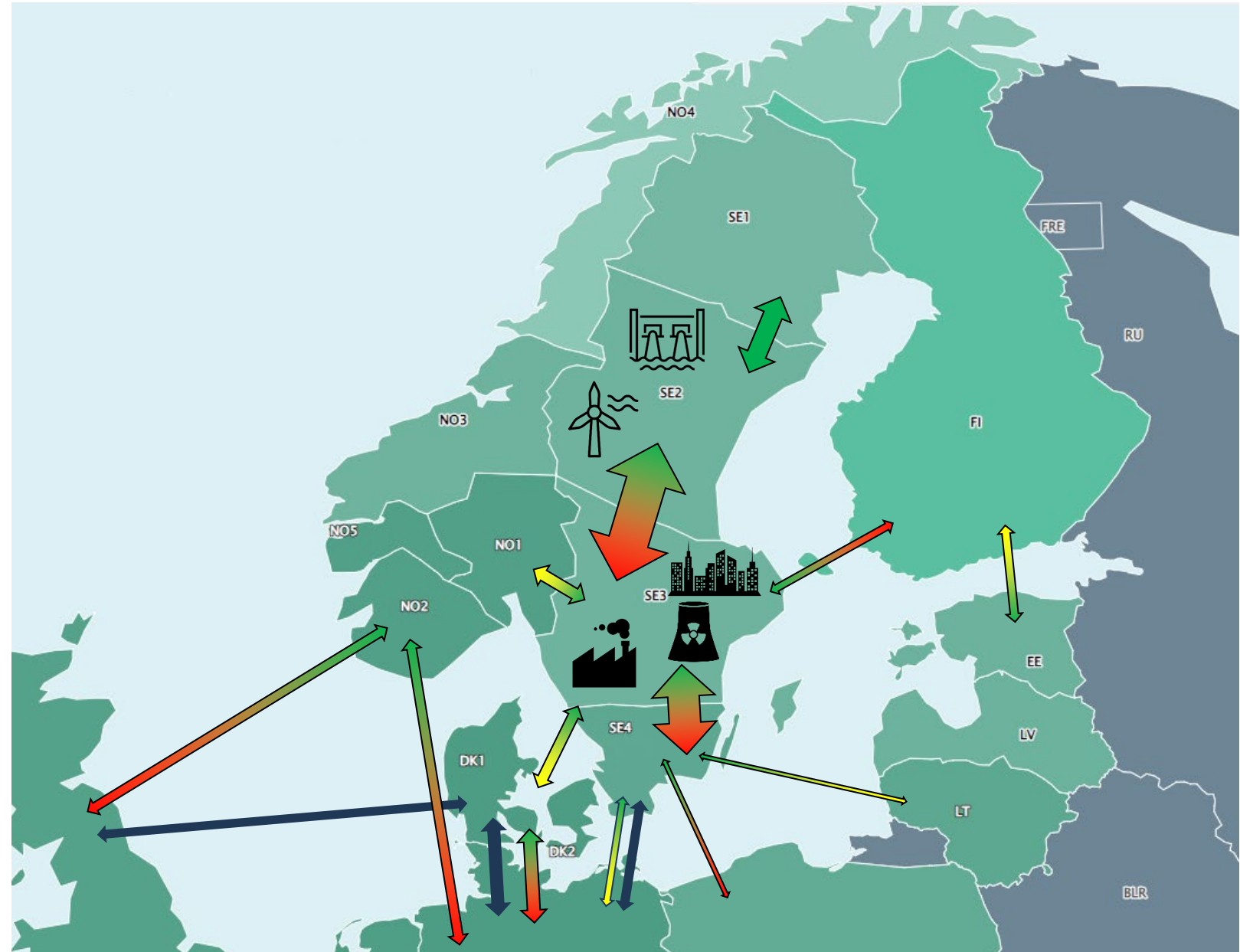

# Green industrial revolution in the north

## Moving green goods instead of green energy

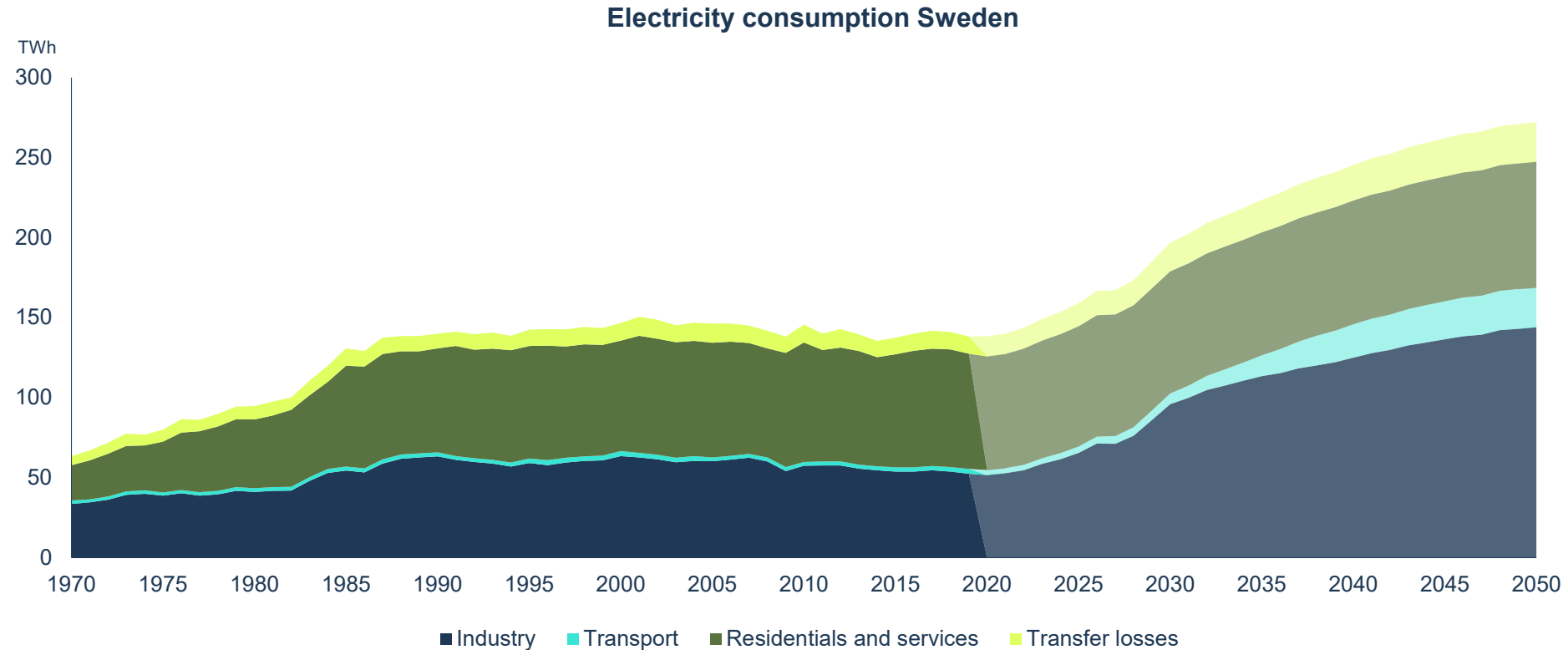

# Demand grows faster than supply in northern Sweden

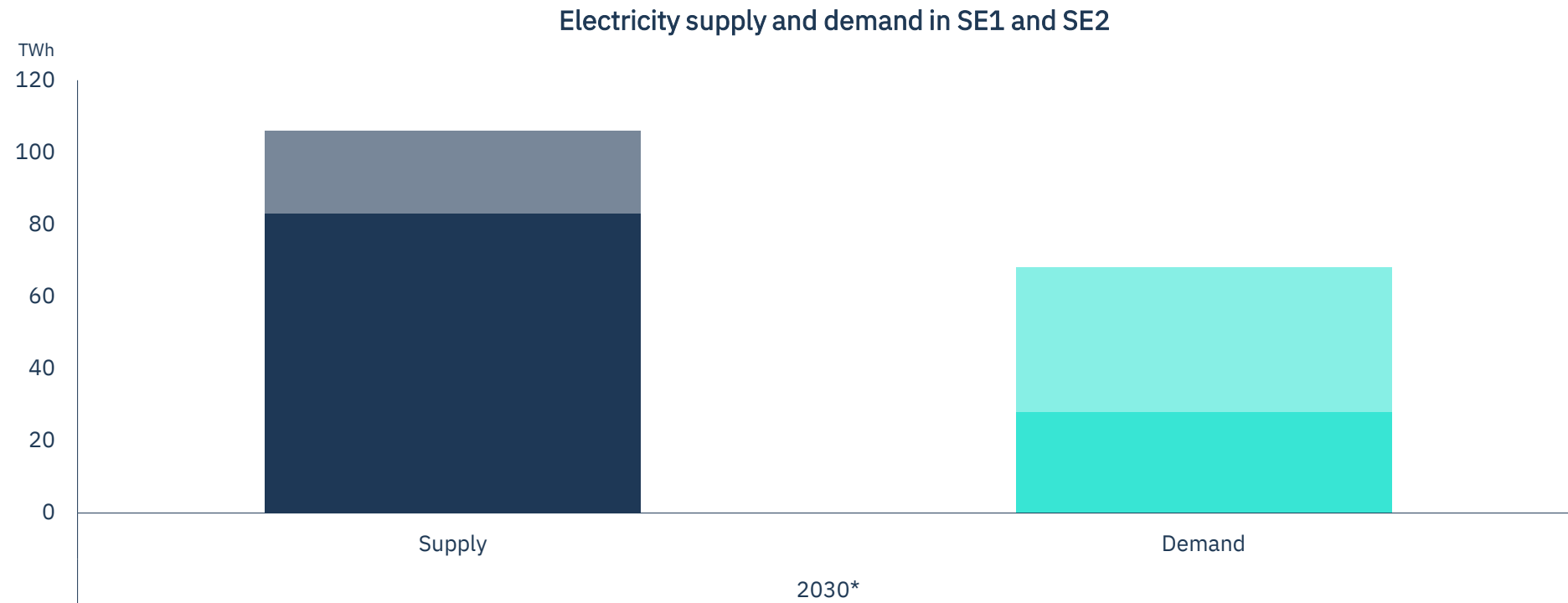



# Energy prices higher for longer

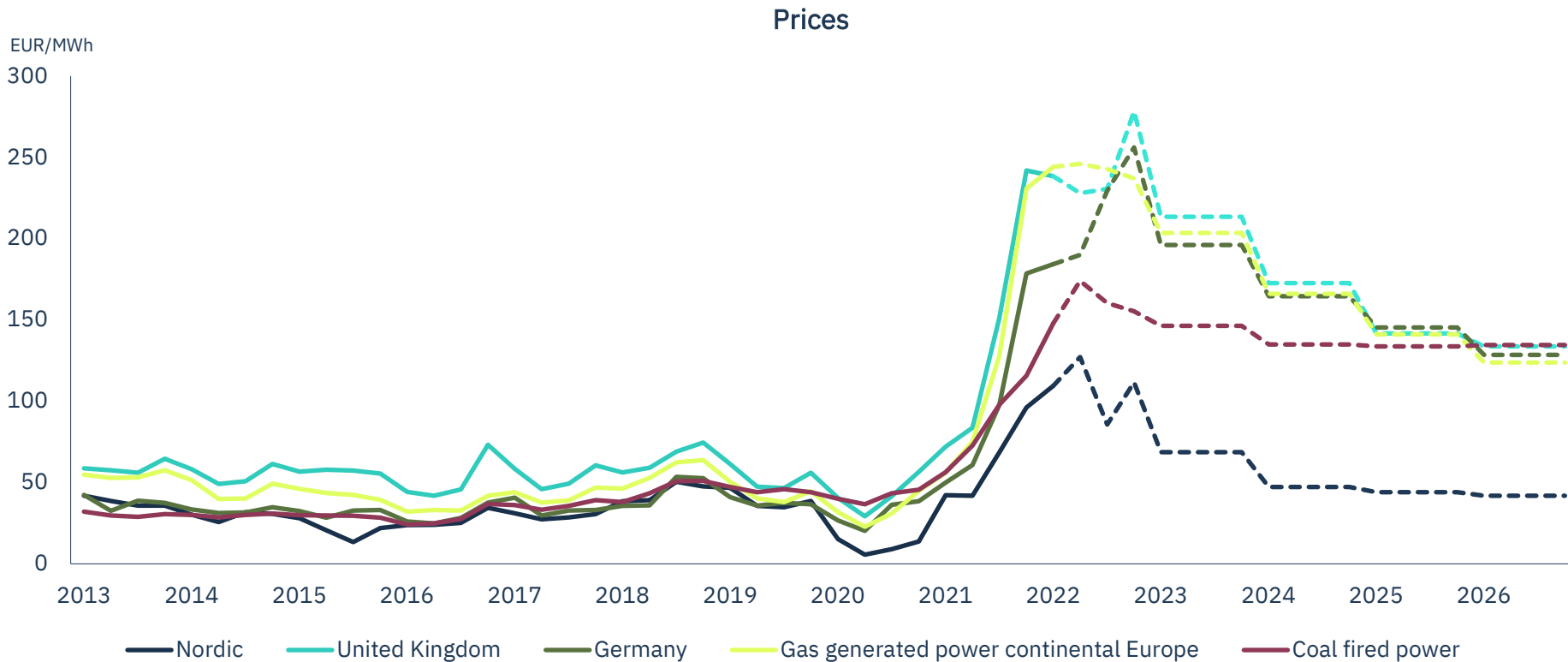

# Low production costs for hydro & wind

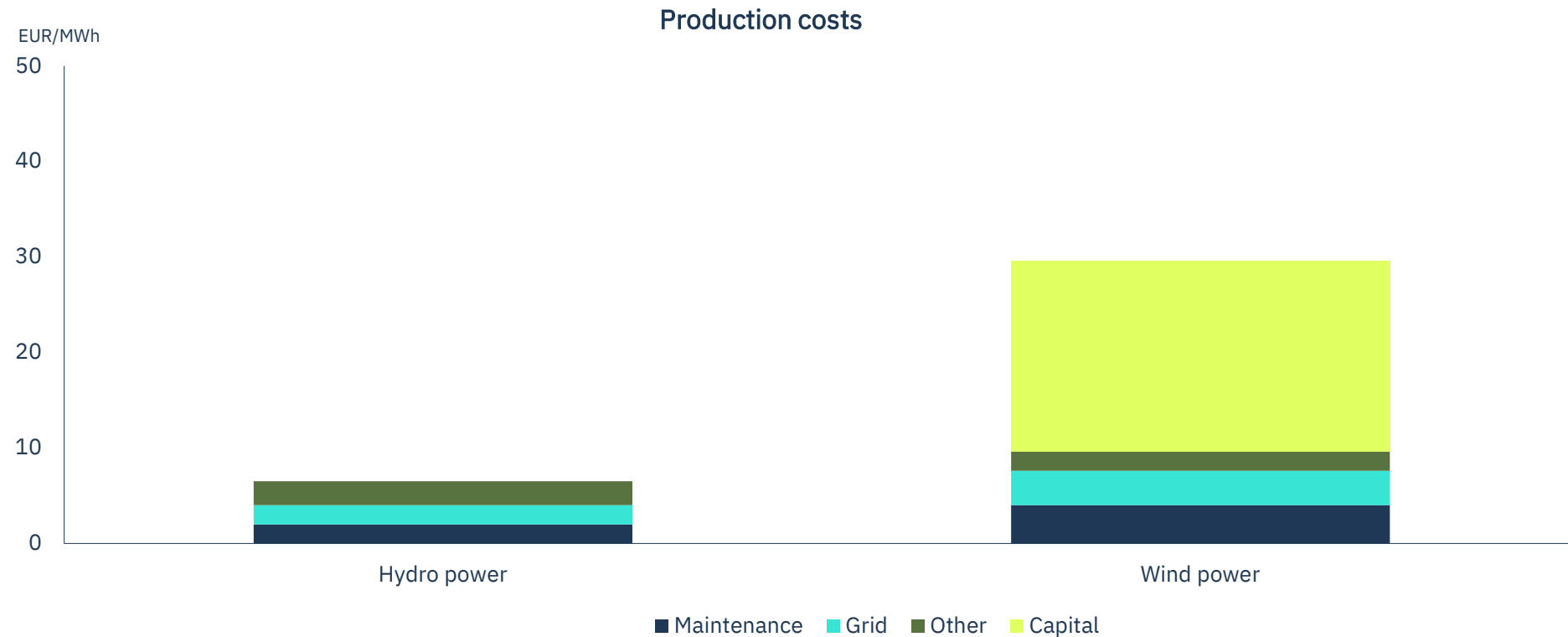

# Forest

**1.3 million ha total land area**

**1.0 million ha productive forest land**

Forest growth and future harvests will increase through active and sustainable forestry. A strong position in the wood market will enable the development of Holmen's production facilities

# Green infrastructure at Holmen

SCALE 1:15 000

EQUIDISTANCE 5 meters



## LEGEND

- Nature reserves
- Voluntary set asides
- Nature considerations at harvesting sites
- Forest managed for industrial use
- Low productive, protected land

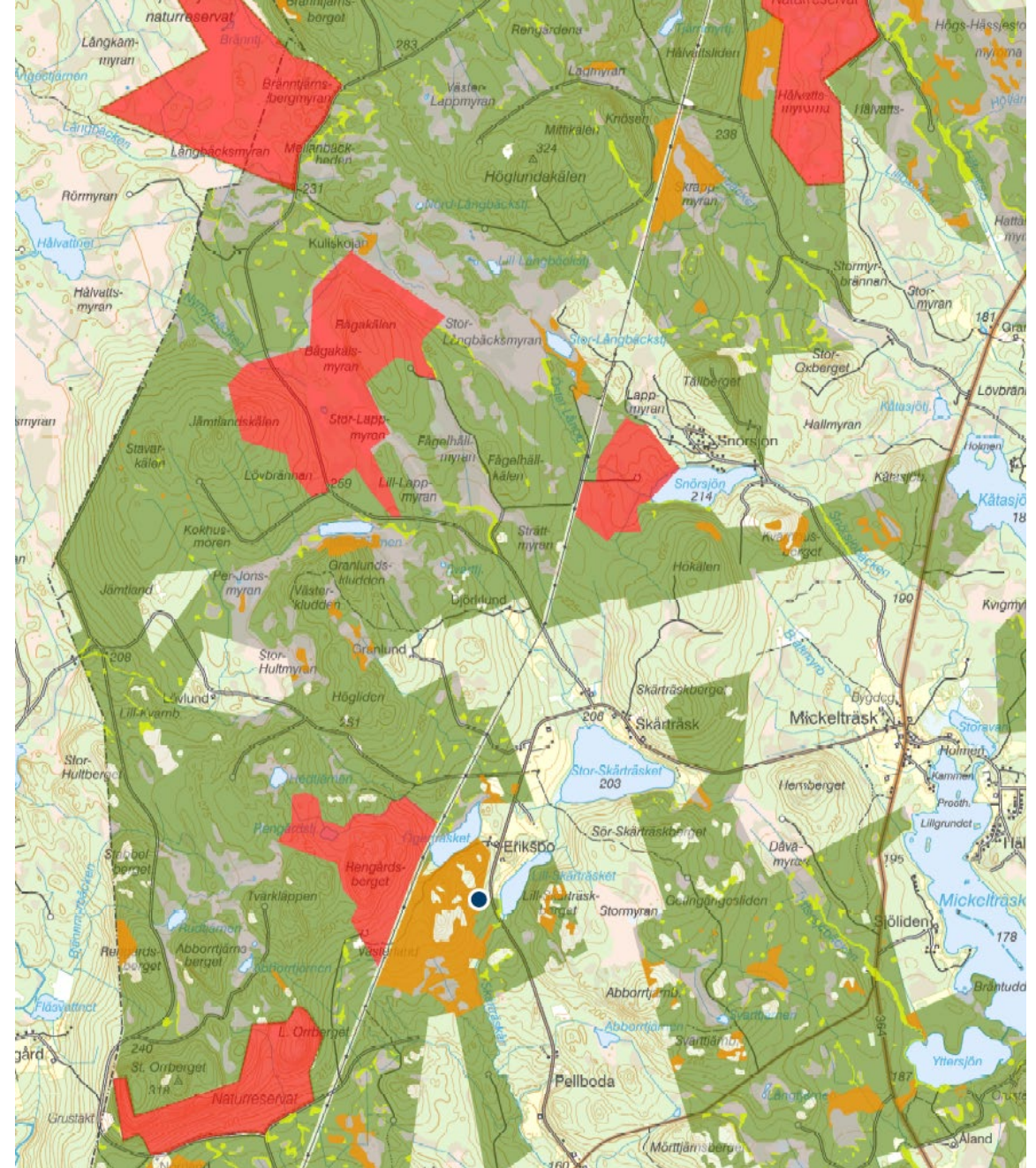

# Strong recovery of deficient elements

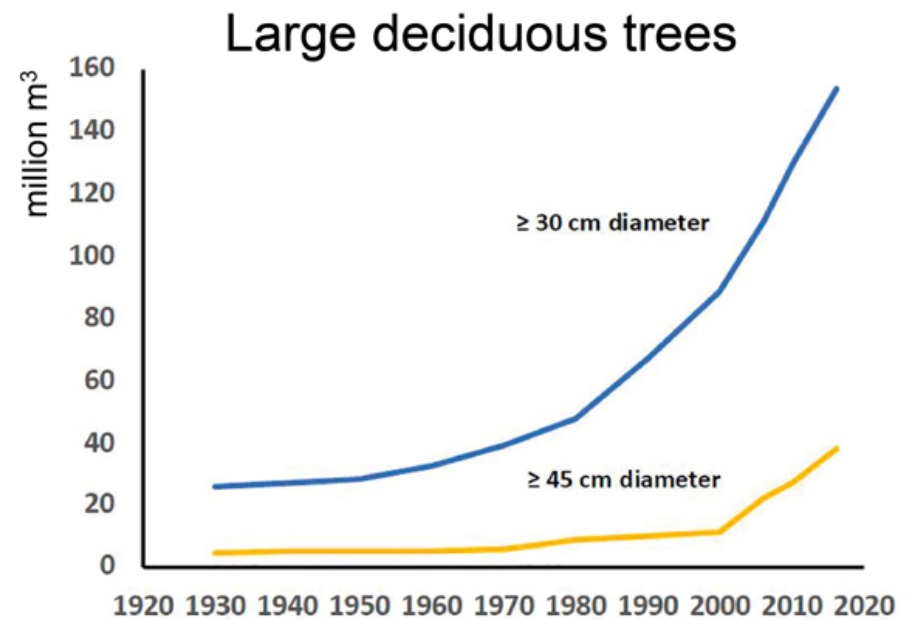
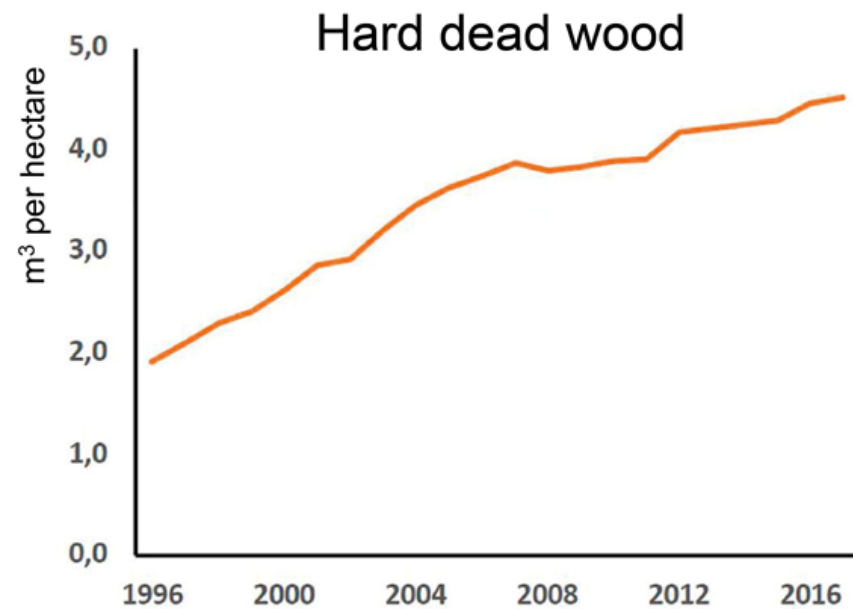

# Wood Products

1.5 million m<sup>3</sup> per year

The Wood Products business will grow through products and solutions for sustainable construction

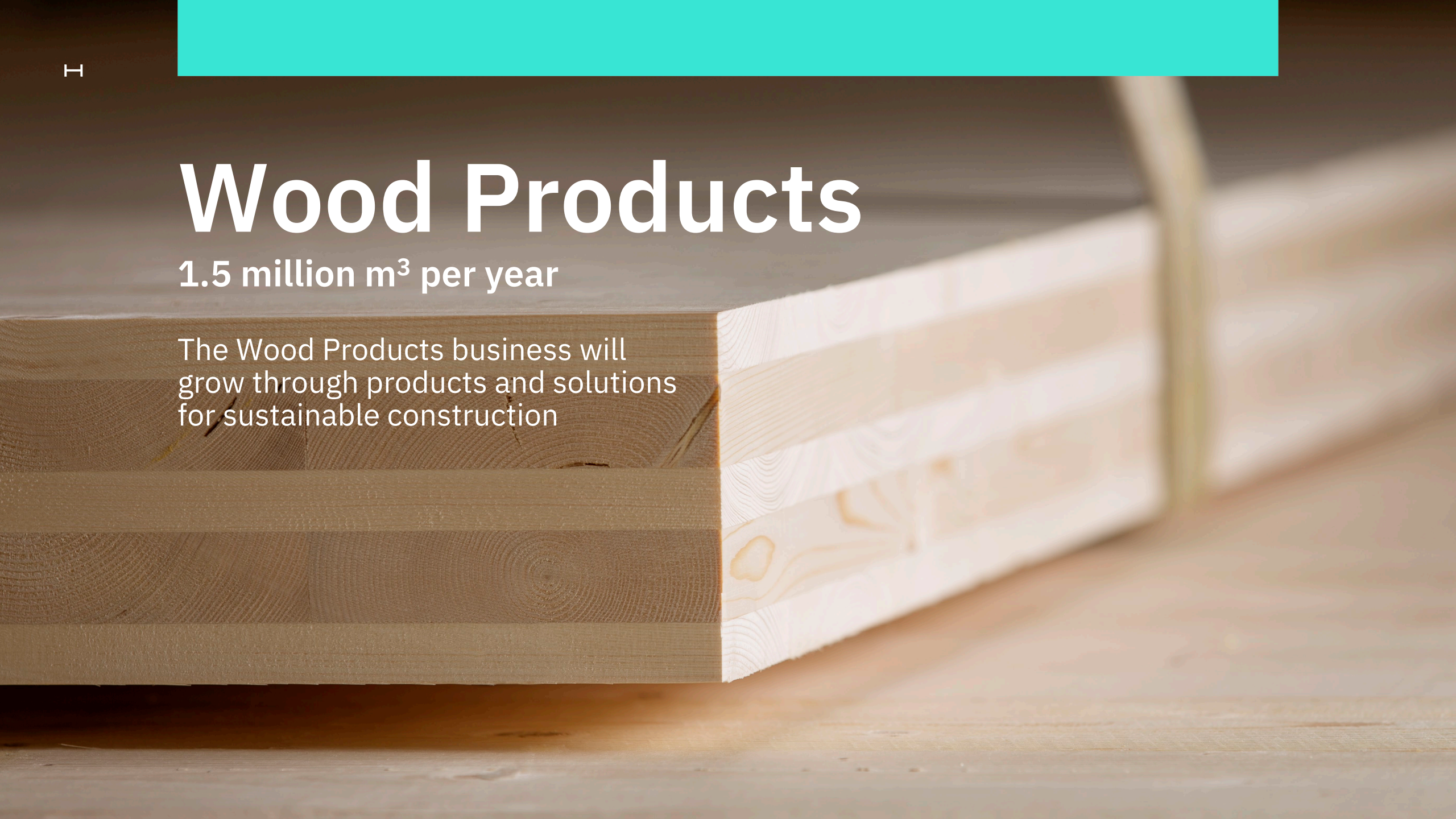

# High demand of wood products

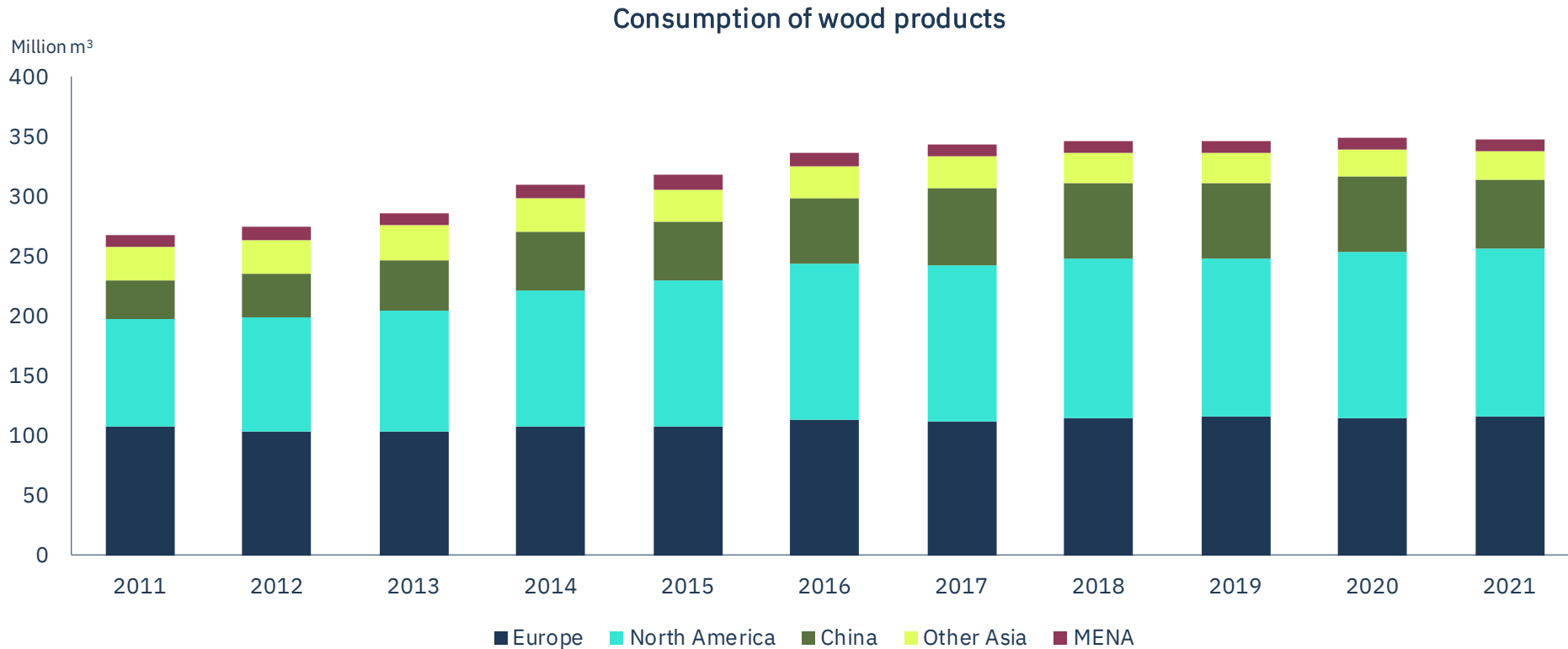

# Increasing uncertainty for major exporters

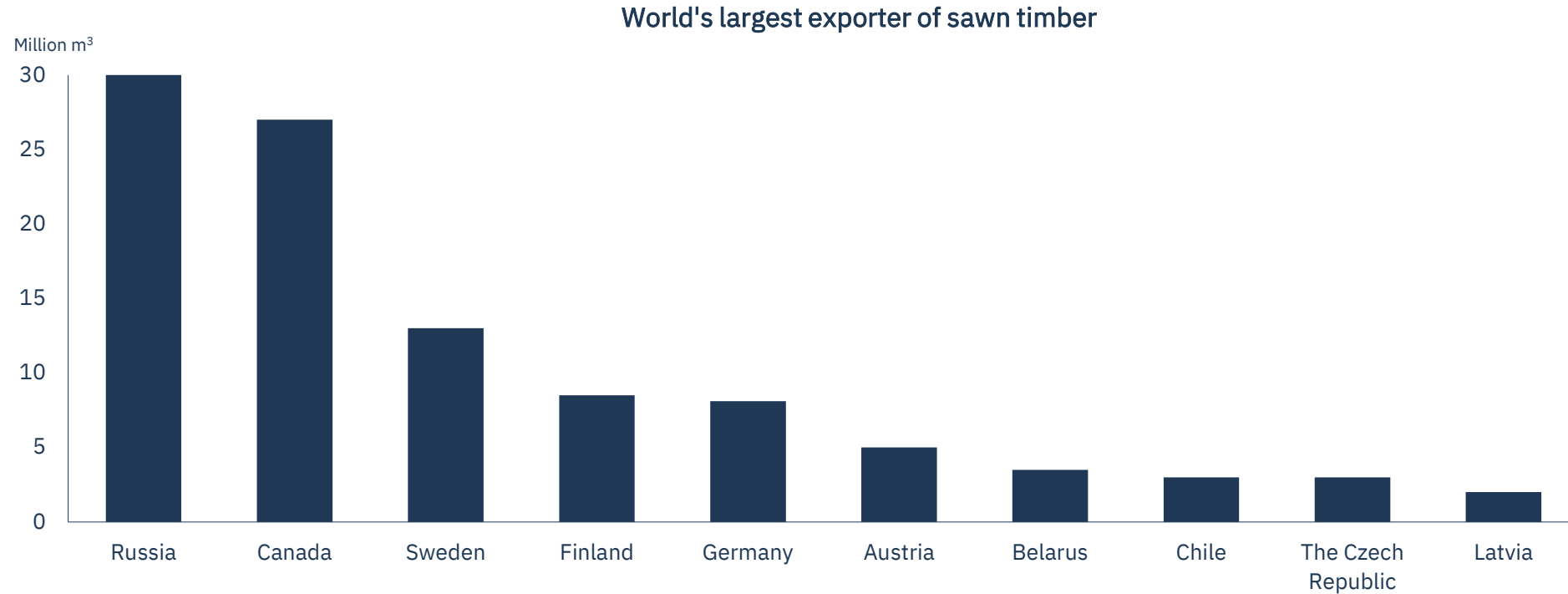



# Scarcity driving up prices

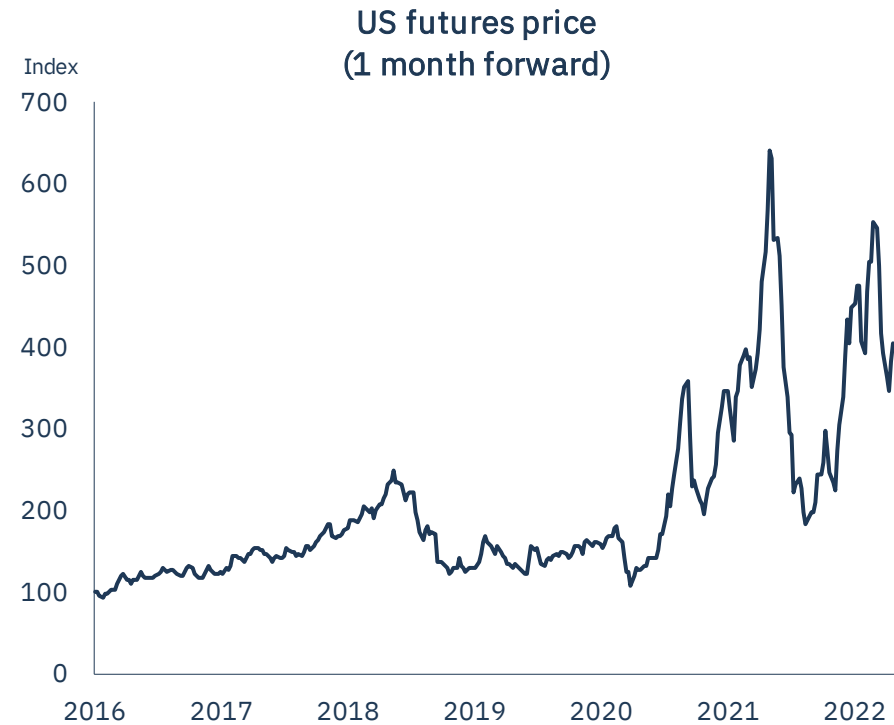
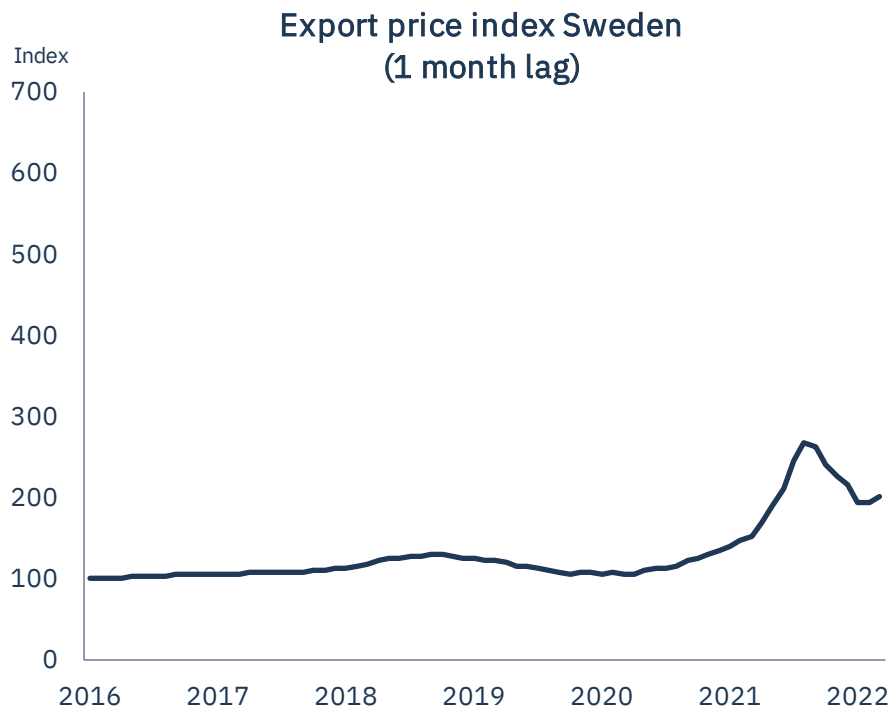

# Well-timed growth

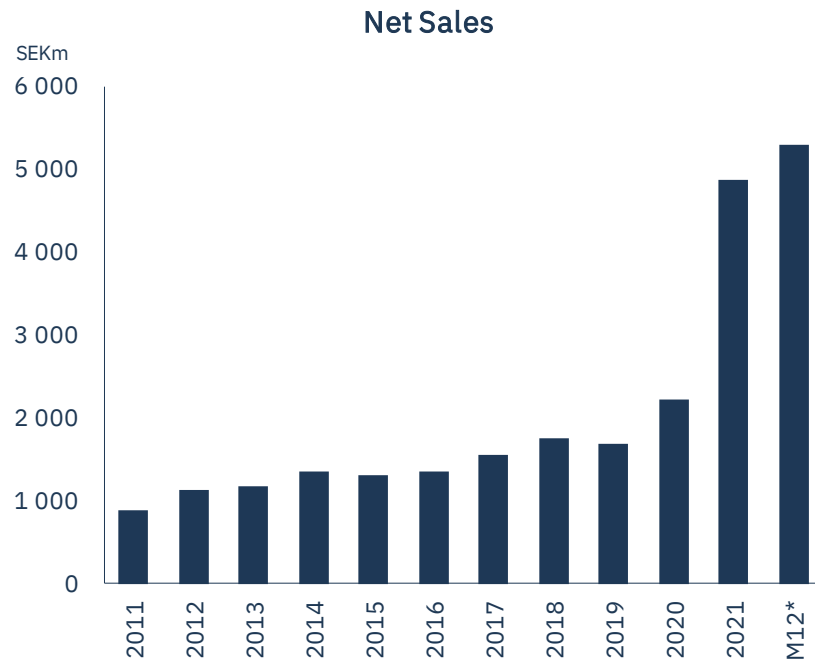

# Expansion of wood products

- Investing SEK 400 million in Iggesund Sawmill
- Capitalising on investments in Braviken & Bygdsiljum sawmills
- Remove bottle-necks in Linghem & Kroksjön sawmills



# Paperboard

550 000 tonnes per year

The Paperboard business will develop on the basis of its position as a market leader in the premium segment for renewable consumer packaging



CHAMPAGNE  
CATTIER

CHAMPAGNE  
CATTIER

# We act on a global market

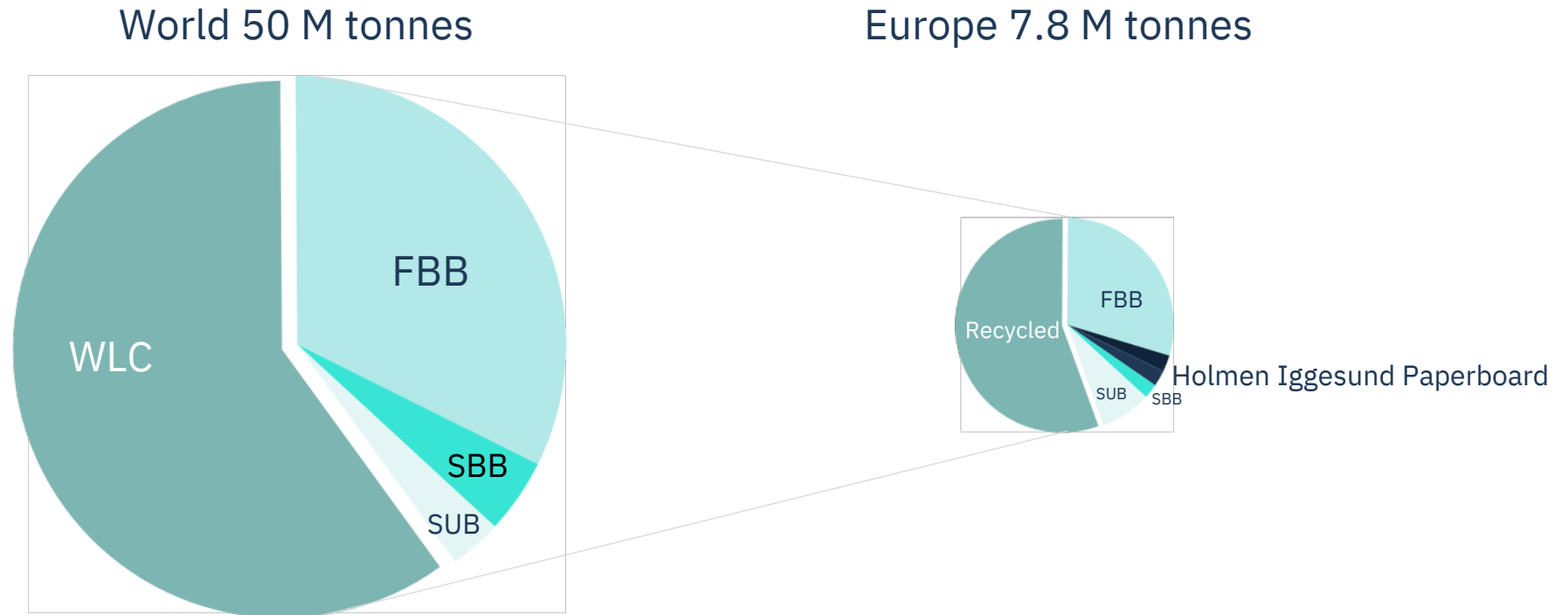

# Healthy consumer board demand in EU

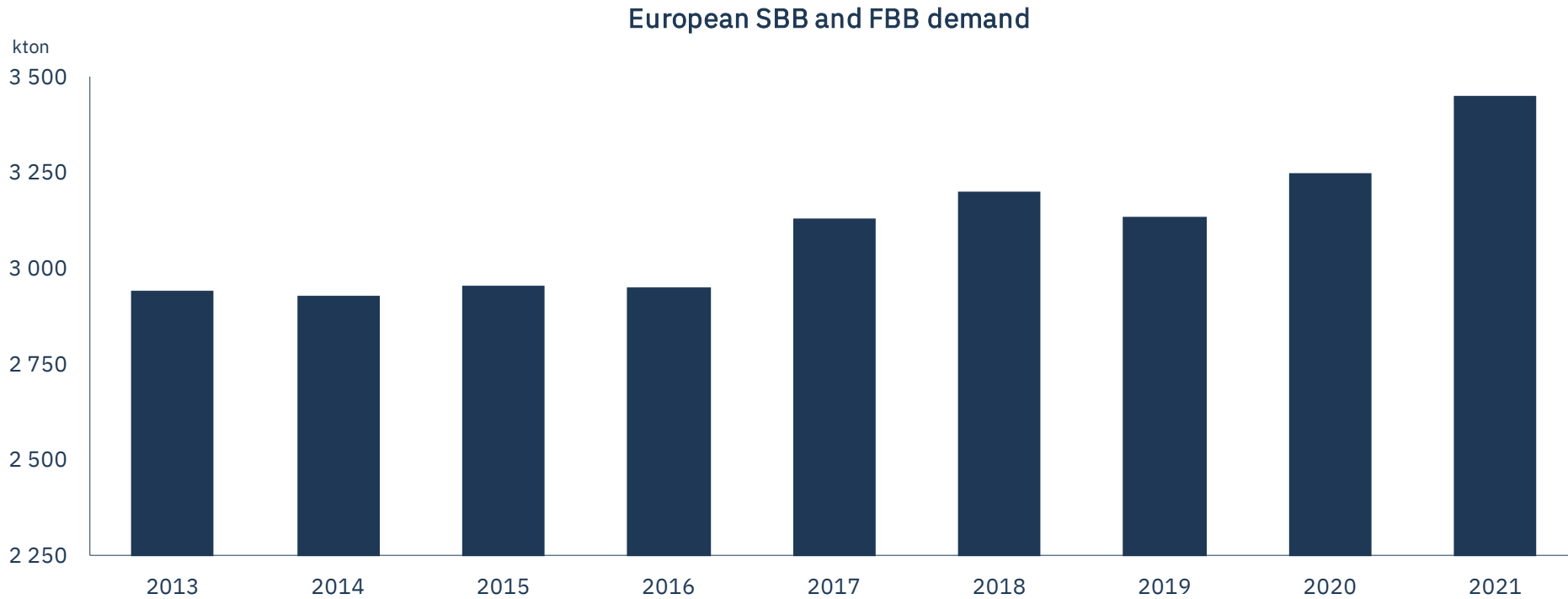

# Cost pressure pushing up WLC-prices

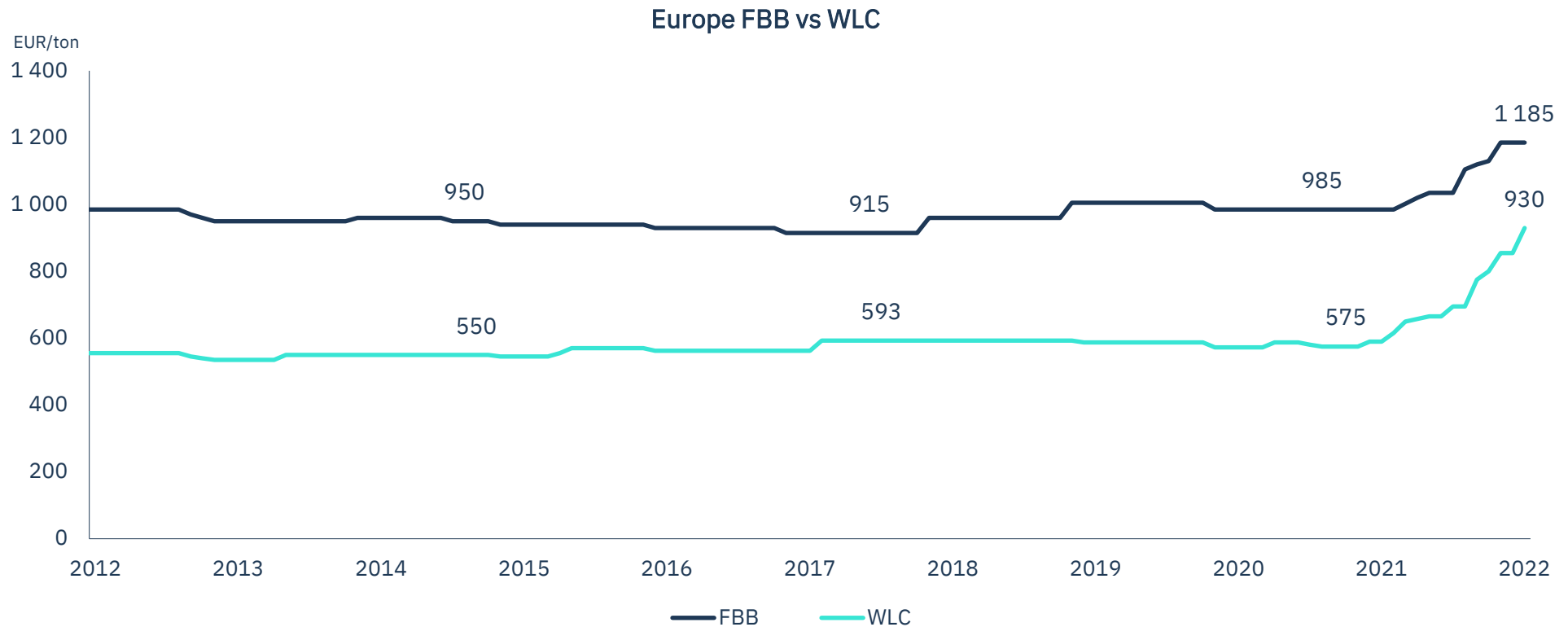

# Focus on premium

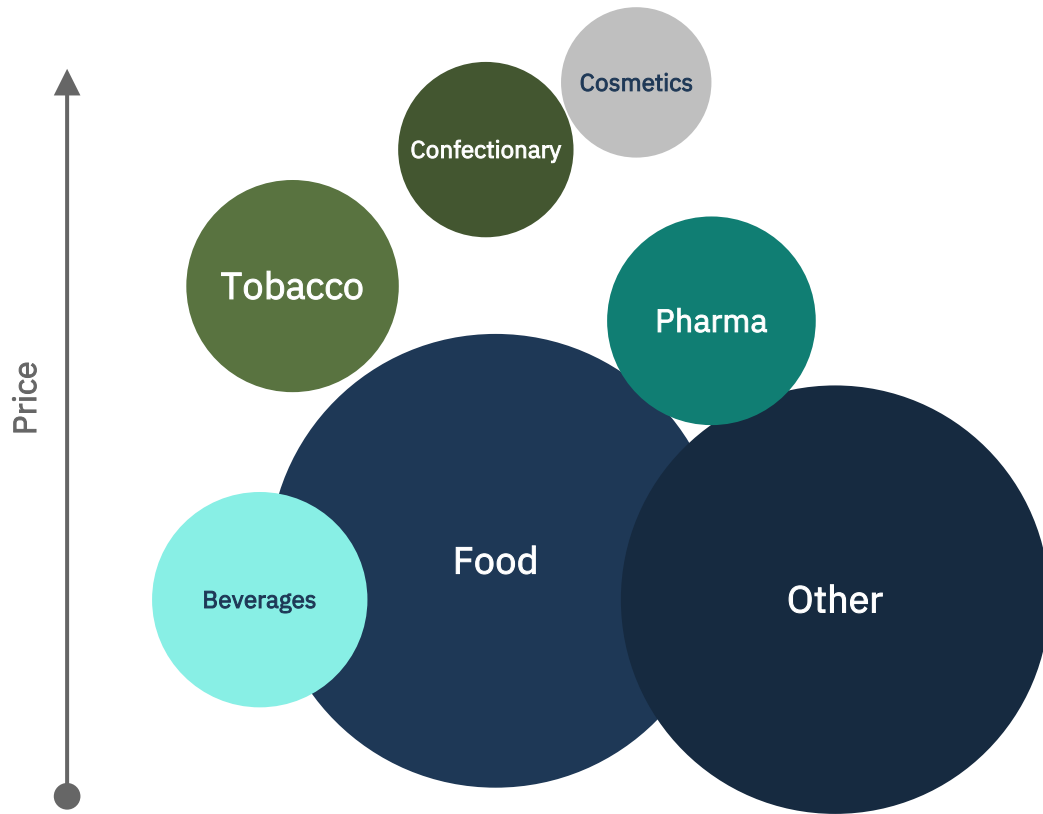

Source: CEPI Enduse Report (WLC, SUB, FBB, and SBB)



CHANEL



CHAMPAGNE  
**TAITTINGER**  
*Reims*



Elizabeth Arden  
NEW YORK



CAROLINA HERRERA

**BOSS**  
HUGO BOSS



## Superior performance

- Strength and durability
  - Giving converters high productivity and lower production costs
- Printing surfaces
  - Whiteness and gloss
  - Light resistance (long shelf life)
- Designer freedom
  - Shaped, cut and formed like few others



# The new premium is quality and sustainability



# Growth by removing bottle-necks

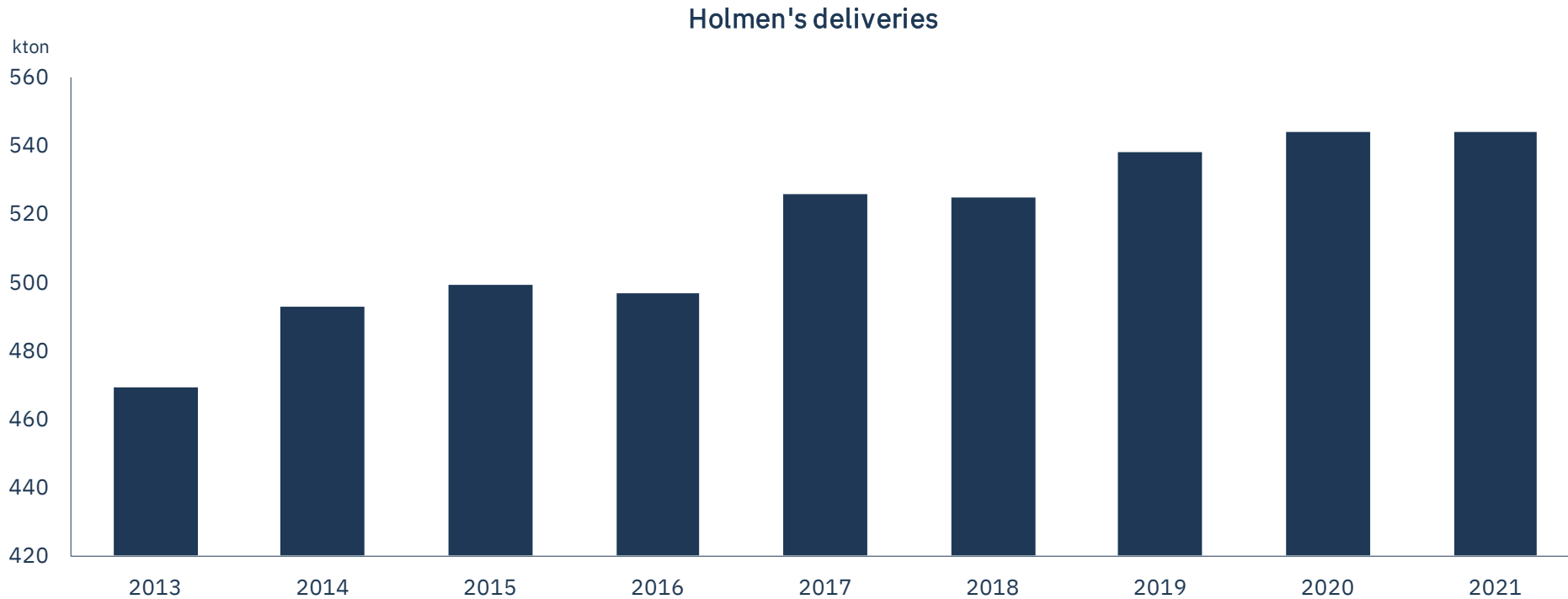

# Paper

1 million tonnes per year

The Paper business is developed by offering resource-efficient innovative alternatives to traditional products



# A market in vast change

- Consumption decline and capacity reduction
- Lack of recycled fibre
- Volatile energy supply and costs
- CO<sub>2</sub> footprint is ever-higher on customers' agendas



# Manoeuvring in a structurally declining market

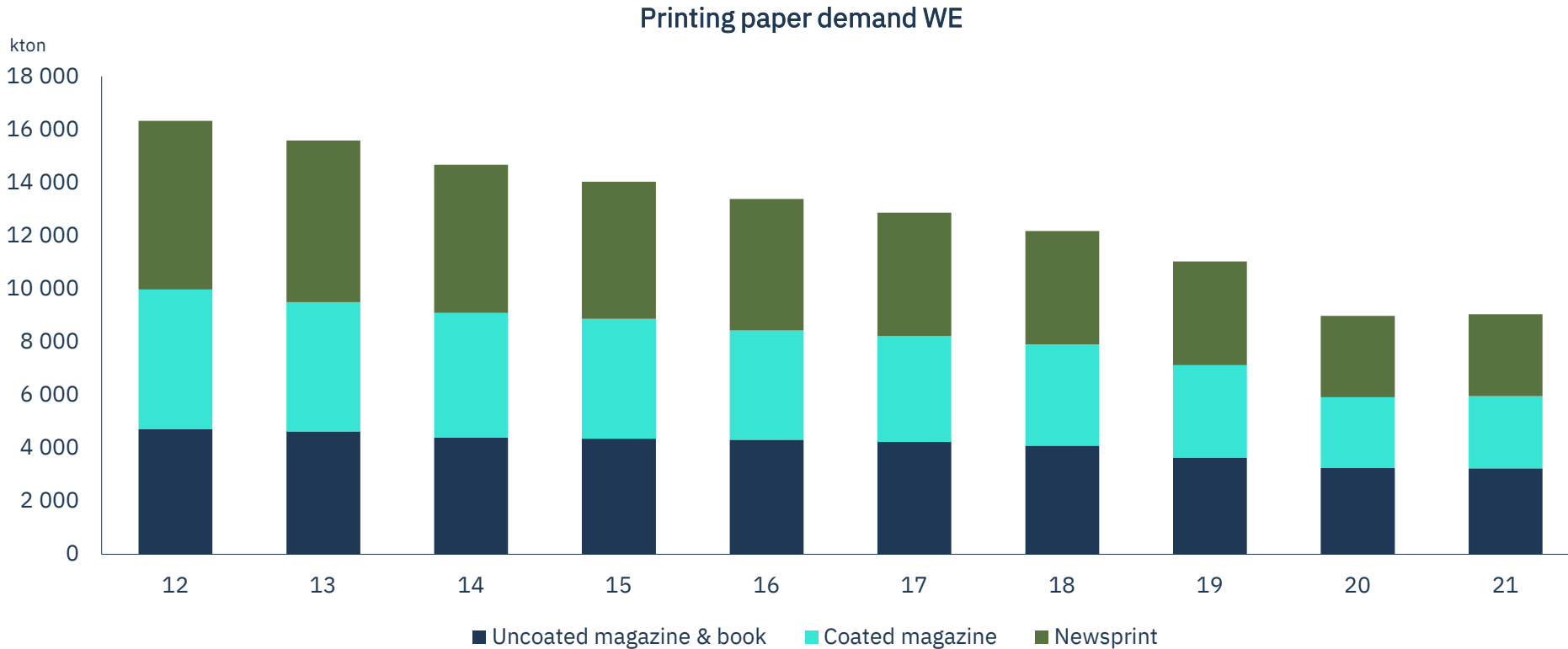

# Retail doing surprisingly well

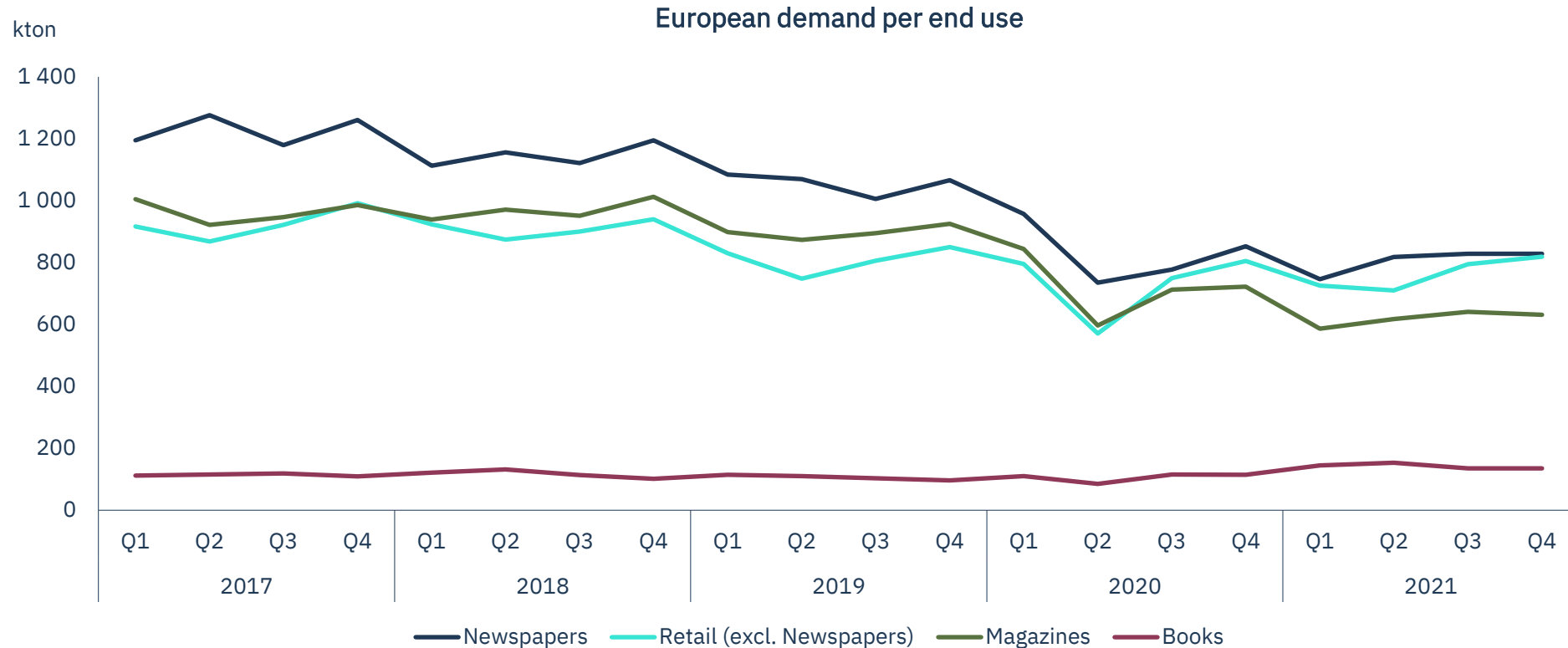

NOTE: Mechanical paper only  
Source: Euro Graph

# Fibre and energy crunch

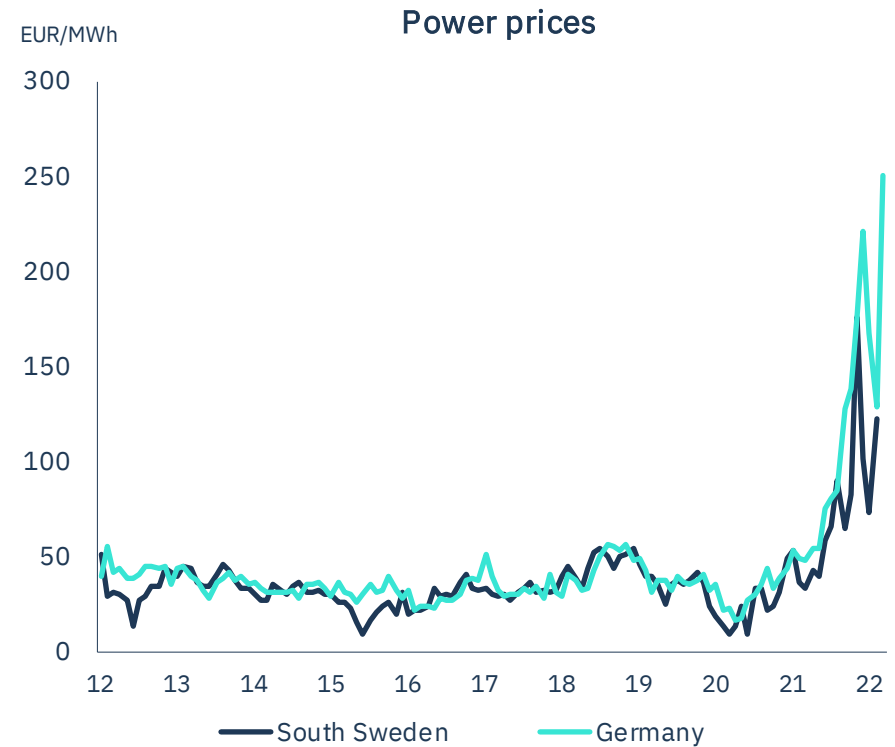
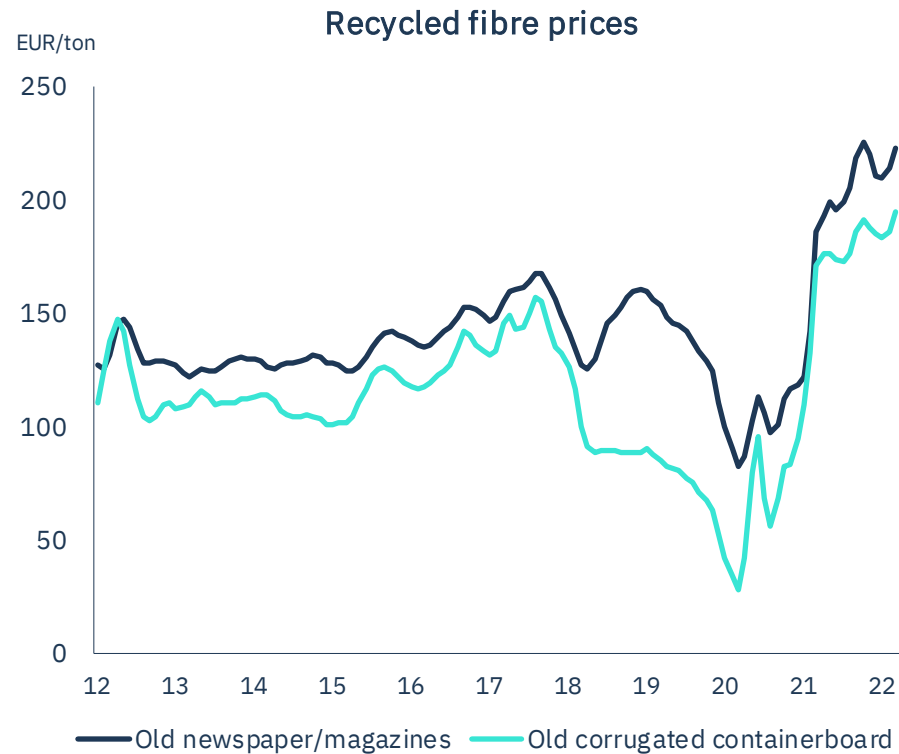



# Close to CO<sub>2</sub> free paper

## Local wood and fossil free electricity

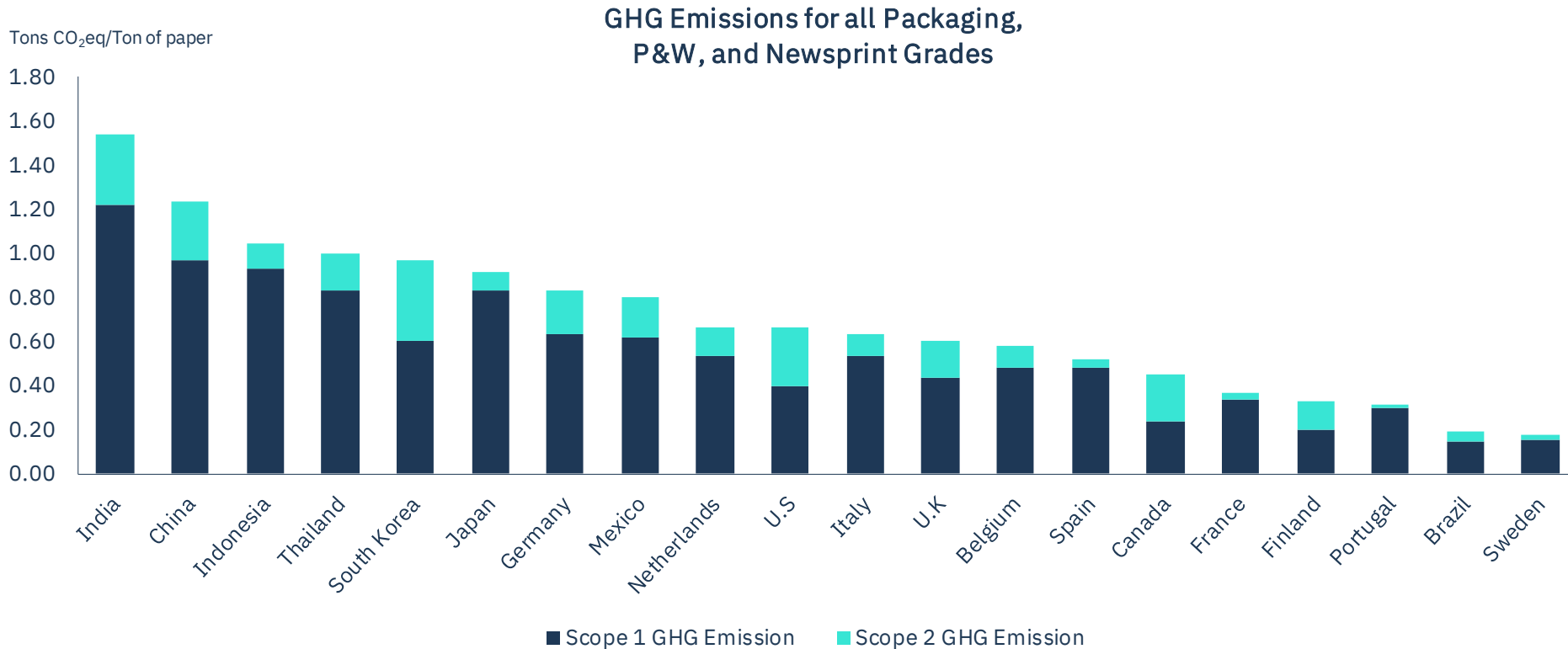

H

**We grow a sustainable future** by offering  
the paper products of tomorrow...

# Continue developing graphical paper... While also looking into new segments

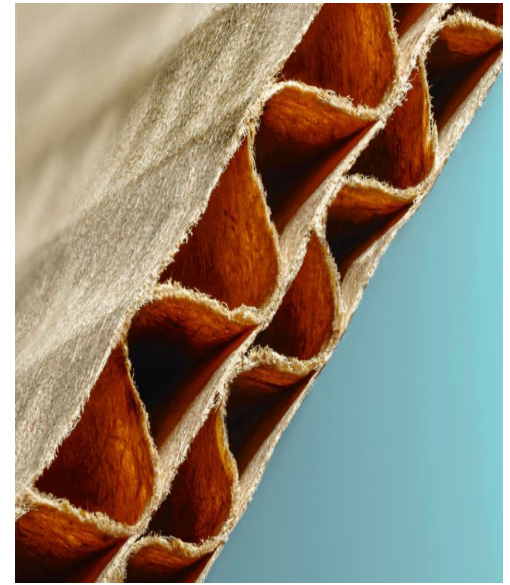
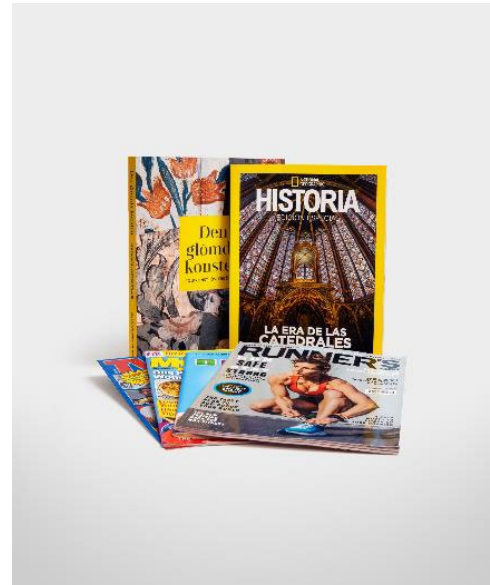

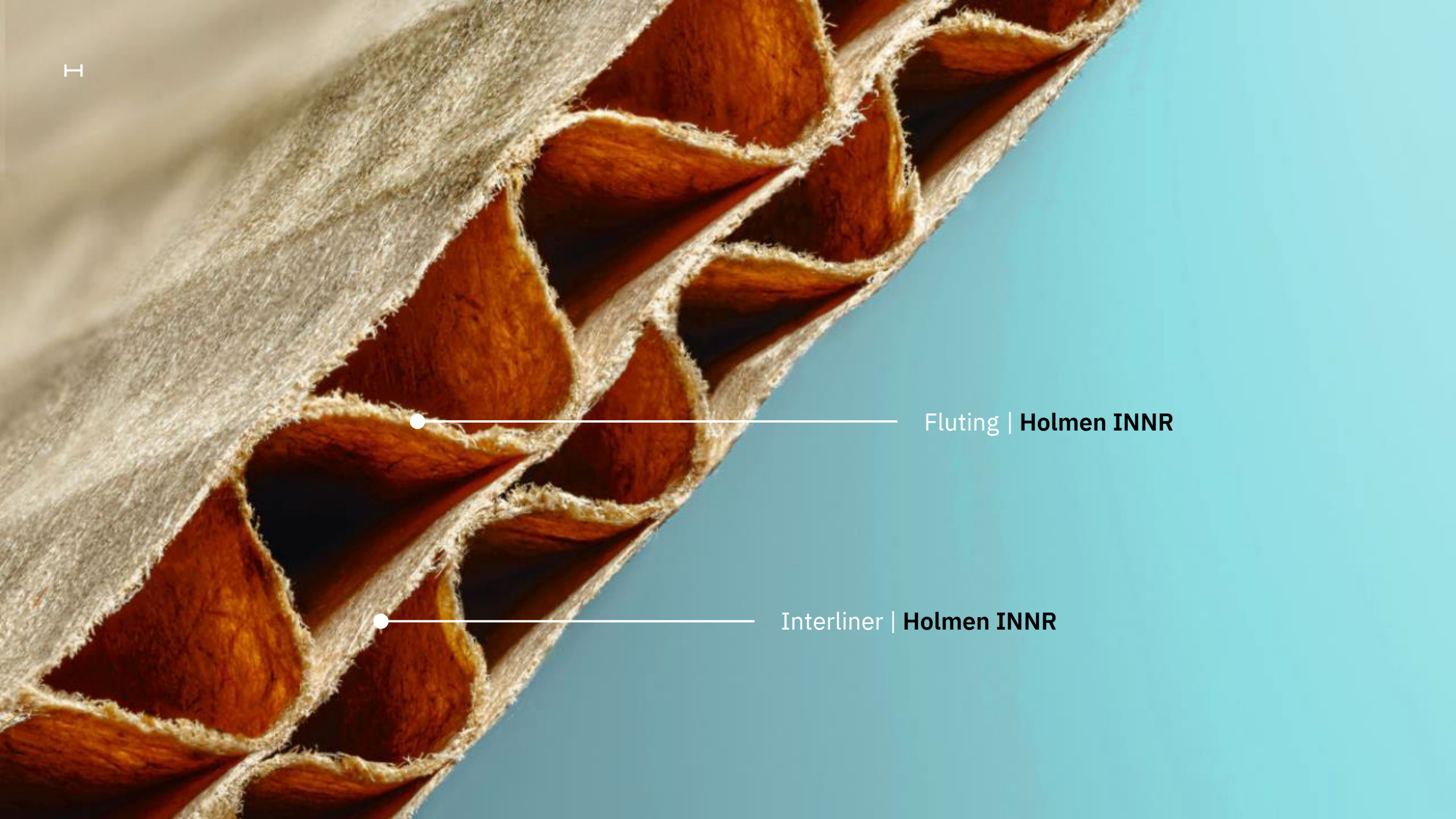

Fluting | **Holmen INNR**

Interliner | **Holmen INNR**

H

# Forest & value drivers



# SEK 47 bn in reported forest value

Based on 3yr average of local transactions

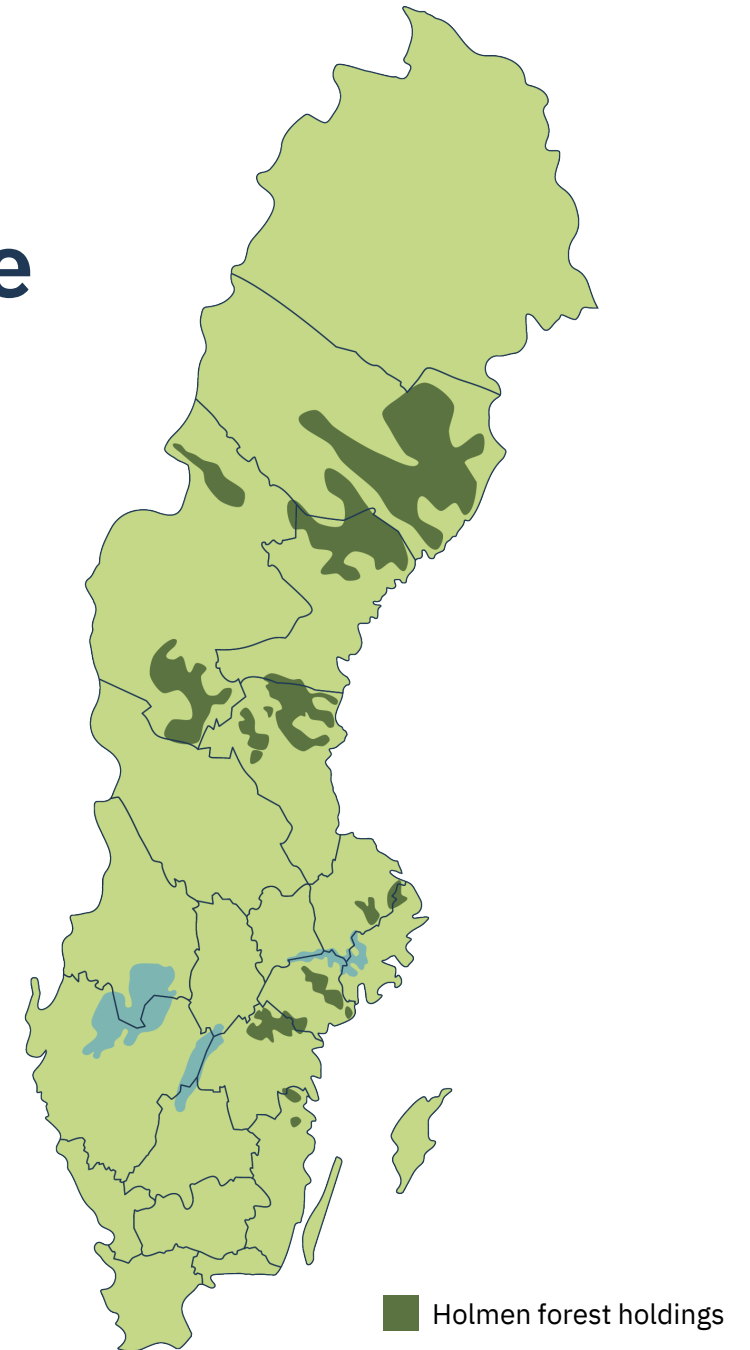
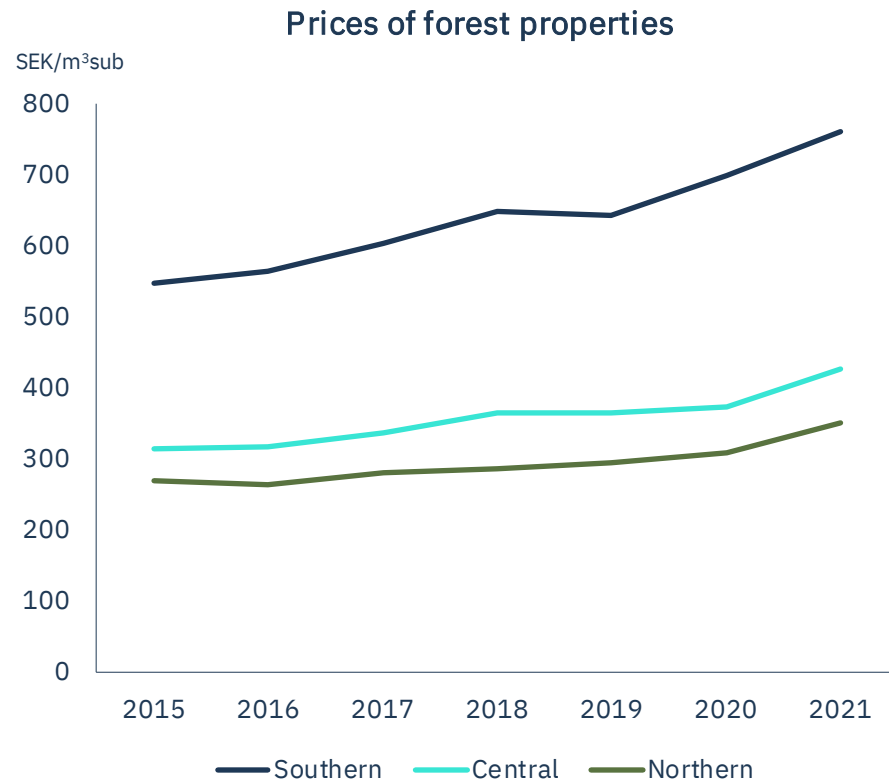

# Sustainably managed forests

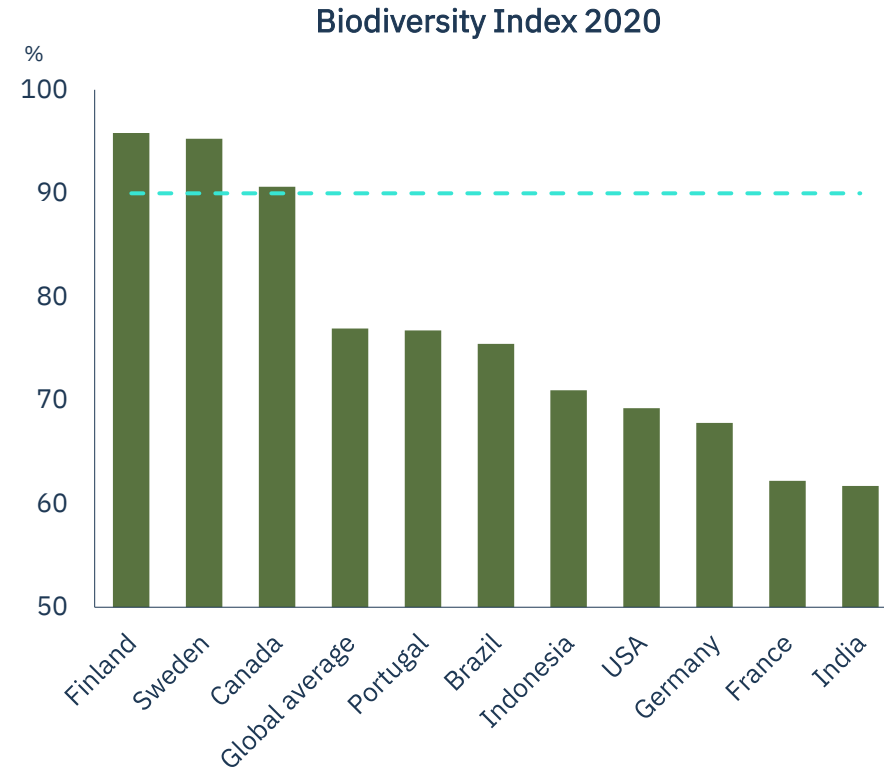
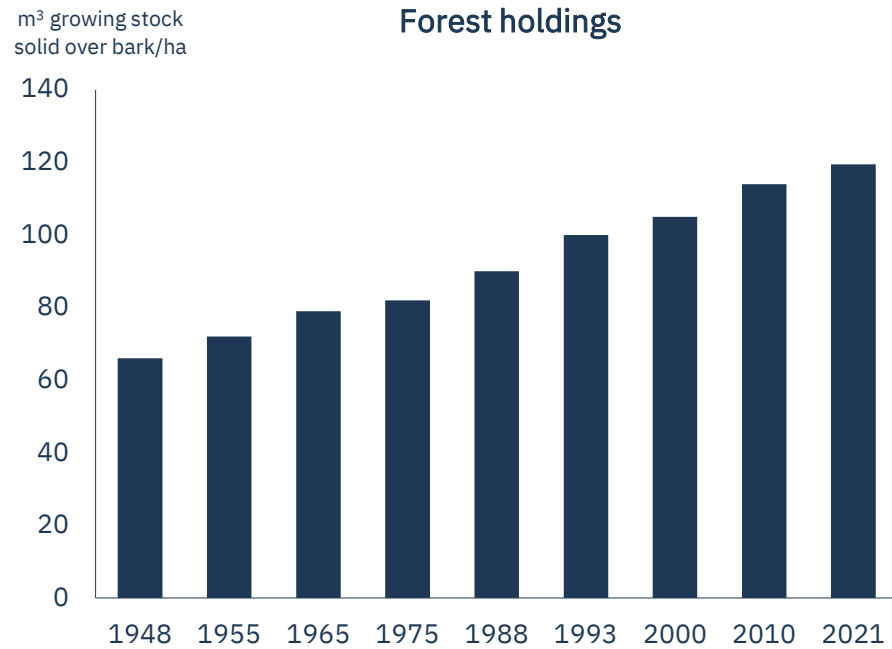

# Gradually increasing harvest

## Selling prices have increased in line with inflation

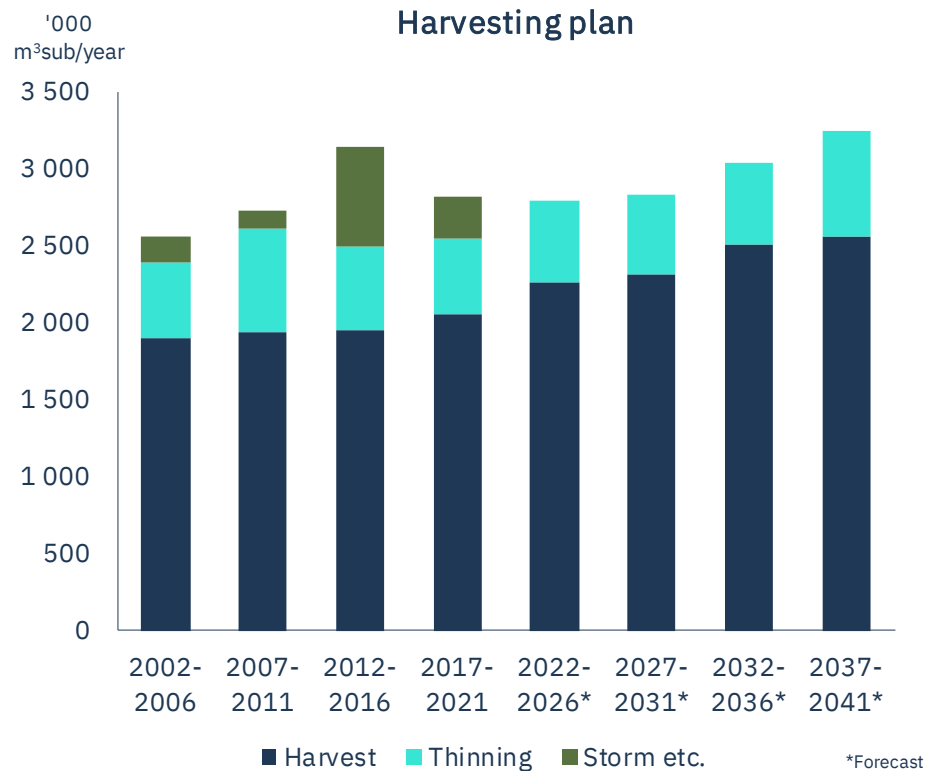



# Global raw material scarcity have had limited impact on wood prices so far

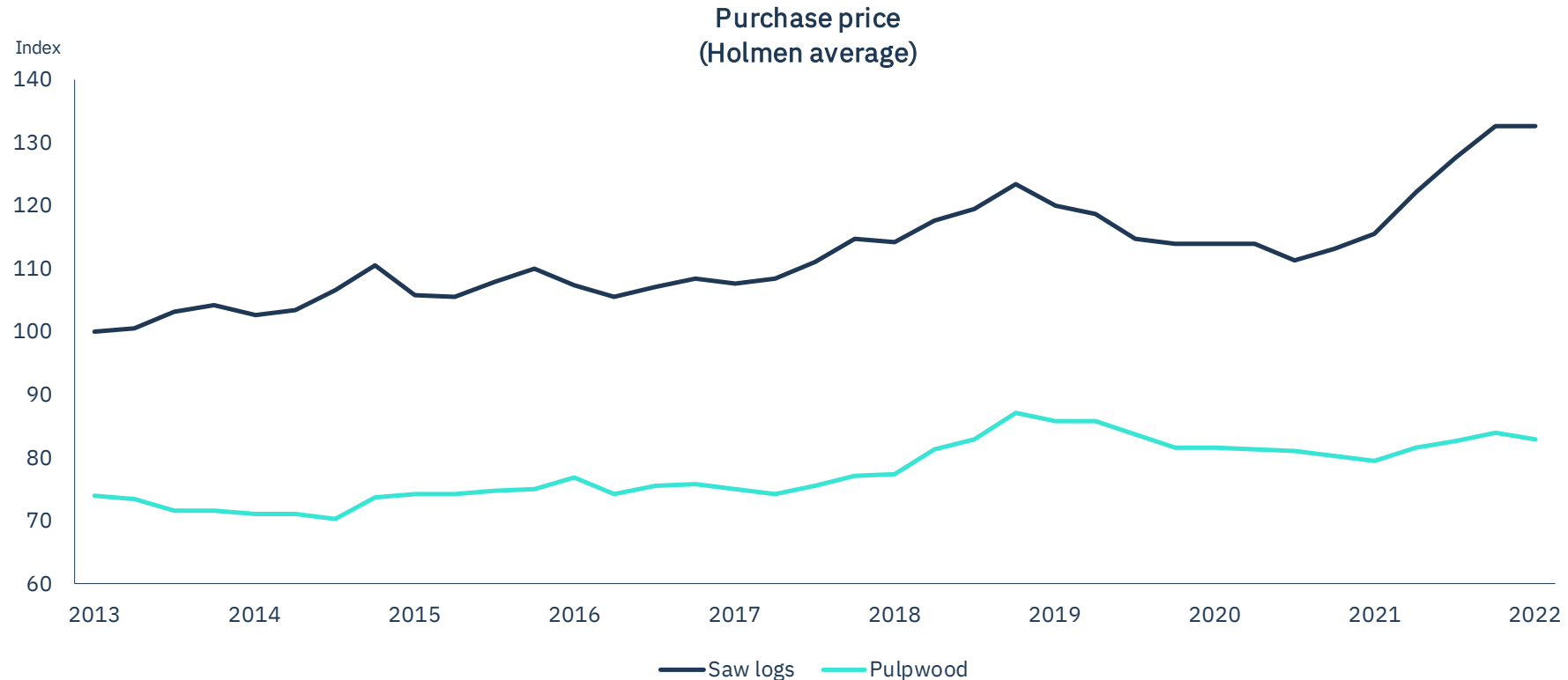

# Record margins adding value to wood

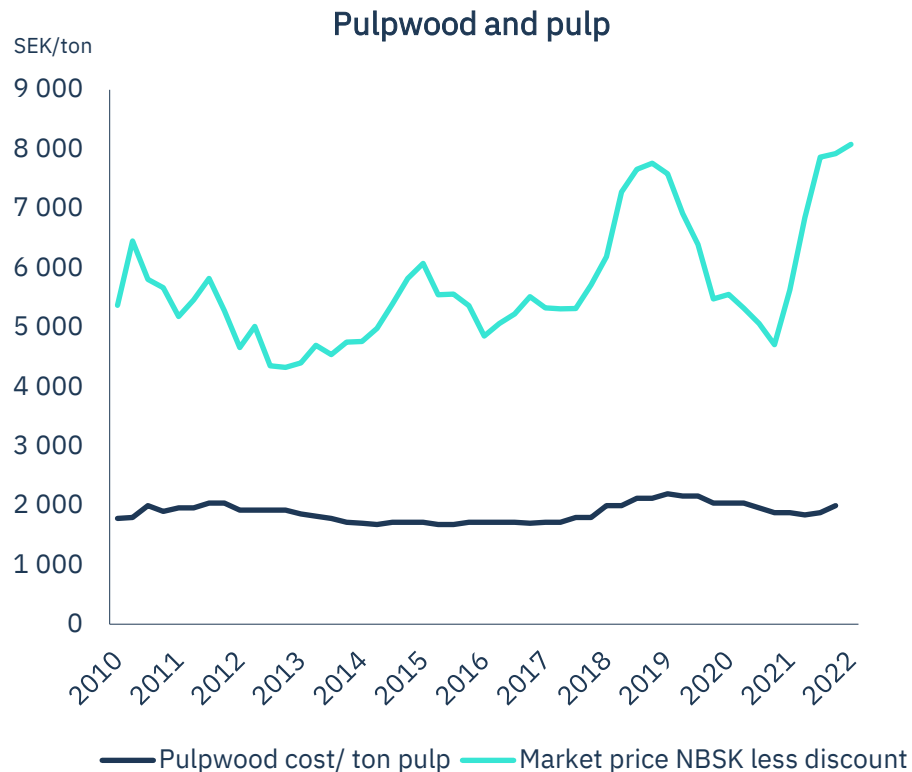

# Log availability an increasing concern for major exporters of wood products

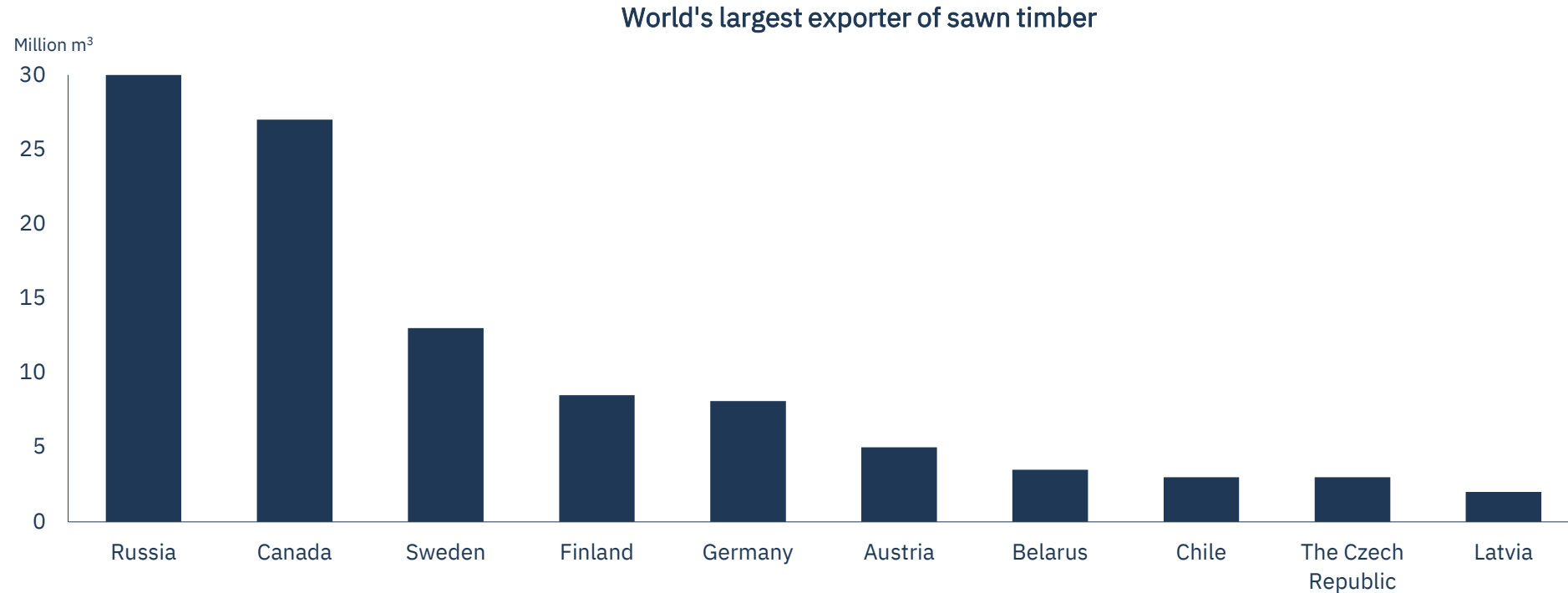

# Infestation driven harvesting in central Europe

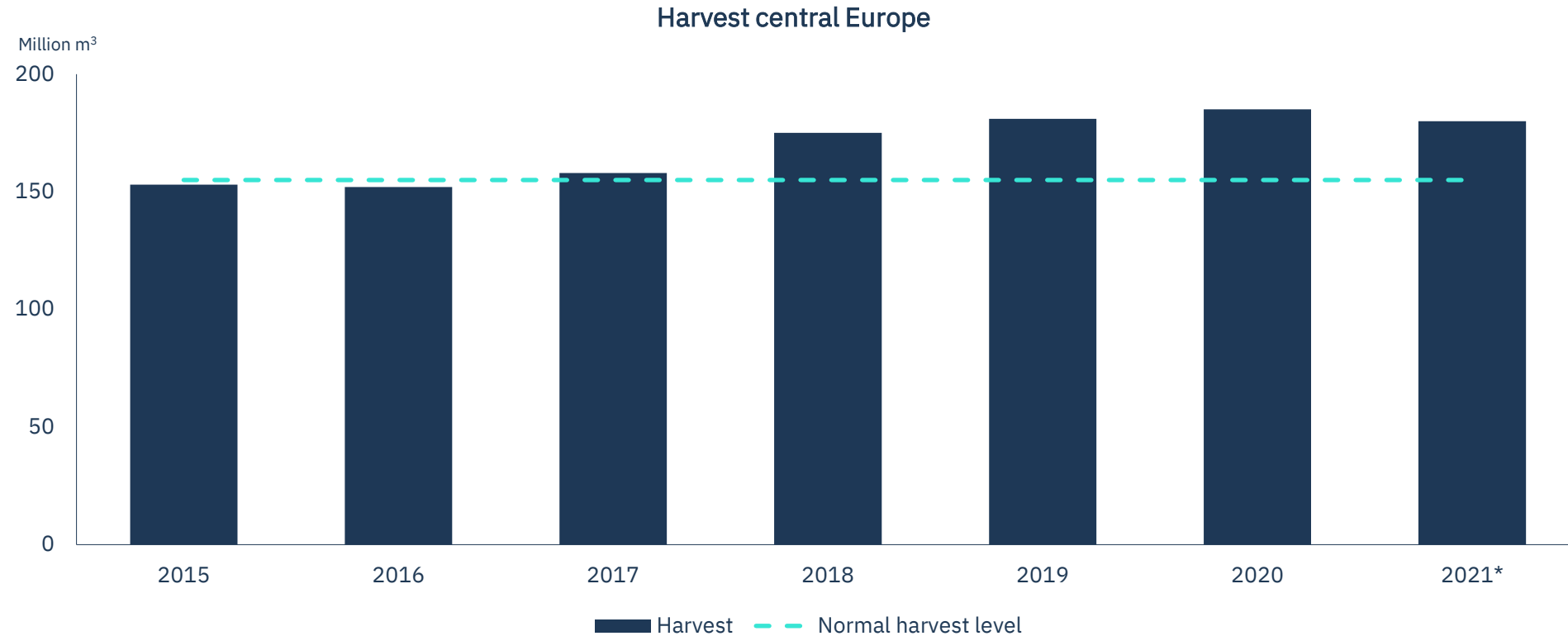

# Sweden & Finland rely on imported pulpwood





**New revenue opportunities  
for a land owner**

# Growing a sustainable future

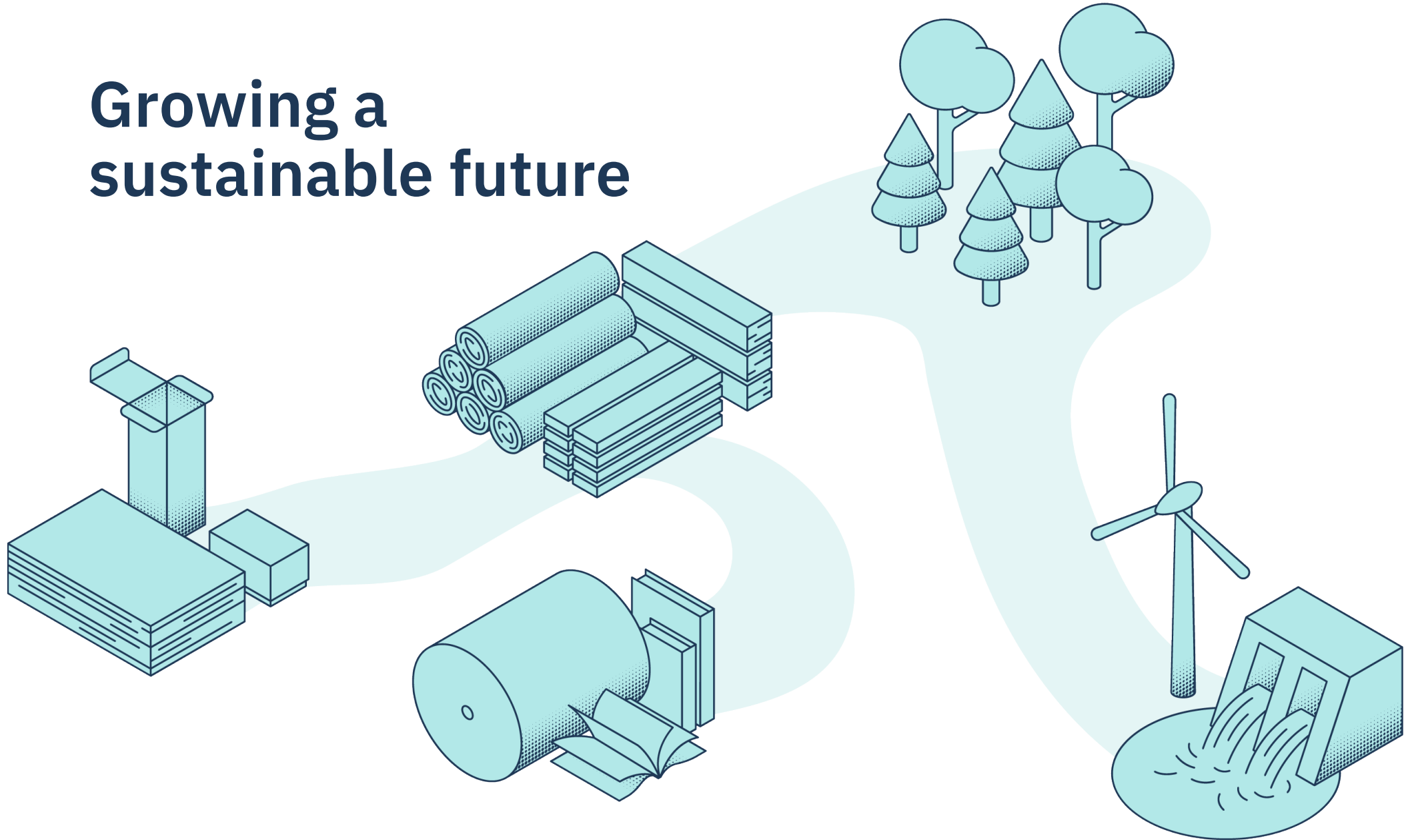

# We grow houses

Leftovers are converted into renewable packaging and paper  
We harvest the energy that blows and runs through our forests

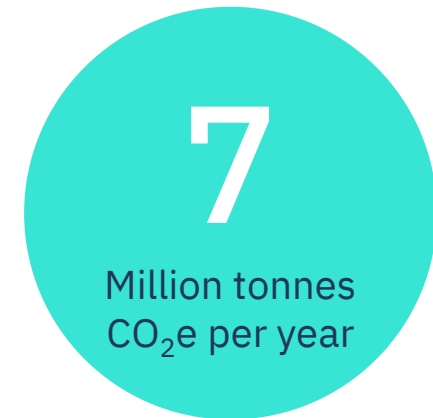
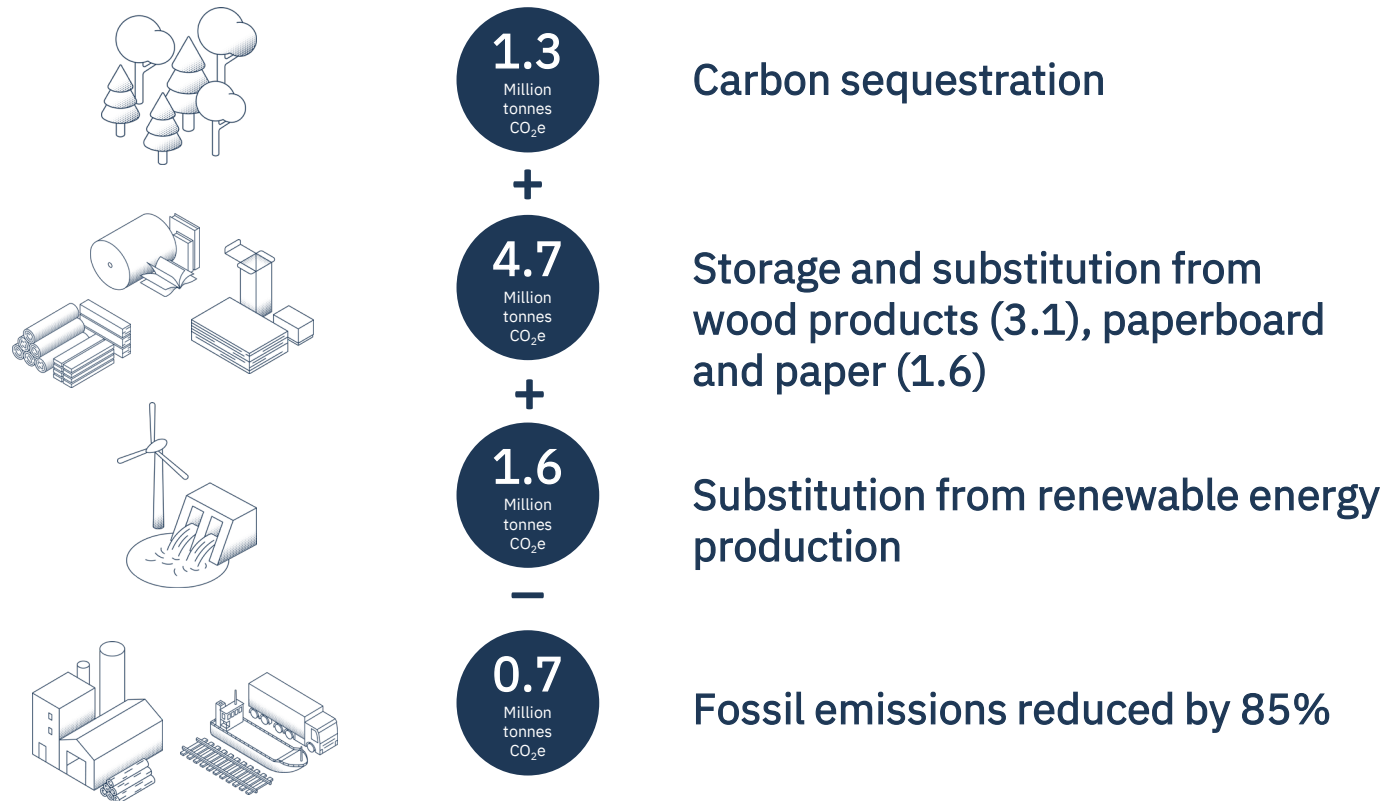



# HOLMEN

[holmen.com](https://holmen.com)